



UR ROUTERS

INSTRUCTION MANUAL No. 5009



MANUFACTURERS E.C. DECLARATION OF CONFORMITY

The following machine has undergone "Conformity Assessment" and is "self" certificated in accordance with:-

Supply of Machinery (Safety) Regulations 1992
and Amendment No. 2063

COMPANY

WADKIN LTD
Green Lane Road
Leicester
LE5 4PF

RESPONSIBLE PERSON

Mr A Lott (Managing Director)

MACHINE DESCRIPTION

TYPE HIGH SPEED ROUTER

MODEL UR

DIRECTIVES COMPLIED WITH

Supply of Machinery (Safety) Regulations 1992
Amendment No. 2063 1994
Draught Proposal CEN/TC 142
ISO 9001 Part 1

SIGNED ON BEHALF OF WADKIN LTD

A handwritten signature in black ink, appearing to be "A. Lott", is written over a horizontal dotted line.

SECTION A - FREQUENCY HEAD ONLY - Page 1/F
SECTION B - BELT HEAD MACHINES ONLY - Page 1/B
SECTION C - COMMON TO BOTH MACHINES - Page 7

LIGHT HIGH SPEED ROUTER

TYPE UR

INSTRUCTION BOOK

Wadkin OPERATING AND MAINTENANCE INSTRUCTIONS

LIGHT HIGH SPEED ROUTER TYPE UR/F

PRINCIPAL DIMENSIONS AND CAPACITIES :-

Centre of cutter spindle to inside of body frame	24"	610 mm.
Maximum distance between table and chuck	11"	280 mm.
Chuck will take cutter shanks up to 9/16" diameter		
Total travel of cutter spindle	4"	100 mm.
Minimum distance between table and chuck	1"	25 mm.
Size of standard table	30" x 27½"	760 x 700 mm.
Width of each table extension wing	10"	255 mm.
Raising and lowering movement of table	6"	150 mm.
Minimum height of table from floor	33"	840 mm.
Spindle speeds in r. p. m. :- for 50 cycles	18,000 and 24,000	18,000 and 24,000
for 60 cycles	18,000 and 25,000	18,000 and 25,000
Alternative speeds available to special order :- for 50 cycles	12,000 and 18,000	12,000 and 18,000
for 60 cycles	10,800 and 18,000	10,800 and 18,000
Floor space, excluding frequency changer, with standard table	30" x 43"	760 x 1090 mm.
Floor space of frequency changer	28½" x 13¼"	725 x 335 mm.
Overall height of machine	65¼"	1650 mm.
Horsepower of motor	2 h. p. at 18,000 r.p.m. 3 h. p. at 24,000 r.p.m.	2 h. p. at 18,000 r.p.m. 3 h. p. at 24,000 r.p.m.
Net weight with standard table including frequency changer	700 lb.	315 kg.
Gross weight with standard table including frequency changer	870 lb.	394 kg.
Shipping dimensions	85 cu. ft.	2-40 cu. m.
Code Word. (Add particulars of electric supply)	Uarer	Uarer

Details included with machine :

Head motor, frequency changer and control gear all fully wired. Cutter guard.

Three Double-ended Guide Pins :-

3/16" (or 5 mm.) diameter and ¼" (or 6 mm.) diameter

5/16" (or 8 mm.) diameter and ⅜" (or 10 mm.) diameter

7/16" (or 12 mm.) diameter and ½" (or 14 mm.) diameter

Two Guide Rollers :

¾" (or 20 mm.) diameter to fit ⅜" (or 12 mm.) diameter pin.

¾" (or 18 mm.) diameter to fit ¼" (or 12 mm.) diameter pin.

One set of collets, set of spanners, oil gun.

A full range of cutter equipment is available for mounting direct in the spindle collet. Additionally, a range of eccentric chucks is available together with a full range of suitable cutters for eccentric operation.

Other sizes of guide pins including taper and graded undersized pins to compensate for cutter grinding are available.

LUBRICATION OF BEARINGS

The bearings are lubricated by a patented system of oil mist lubrication and therefore it is important to use the oil and to lubricate the bearings to instructions given on page . Since the introduction of our patented system, the special high speed ball bearings (which must be purchased from "WADKIN LTD") have given exceptional performance, but as no guarantee can be given against bearing failure which could be attributable to over lubrication OR other causes, it is recommended that the lead is returned to us for repair. We have a Service Department where the work is undertaken with the minimum delay.

Where machines are shipped abroad this service arrangement cannot economically be given. Under these circumstances a description of how to dismantle the lead is give on pages ' and

A device to assist with the removal of the ROTOR is included with export machines.

LOOSE END PLUG INSERTED IN
SPINDLE TO TAKE THRUST OF SCREW.

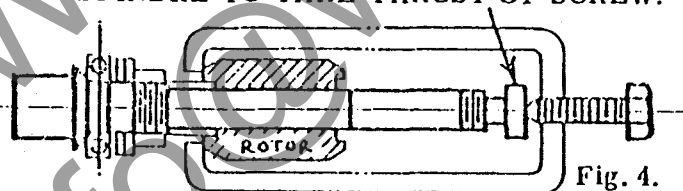

SCREW JACK FOR REMOVING ROTOR.

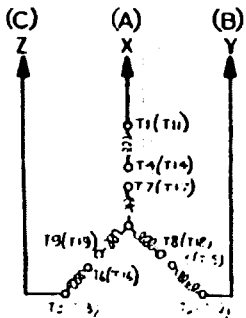
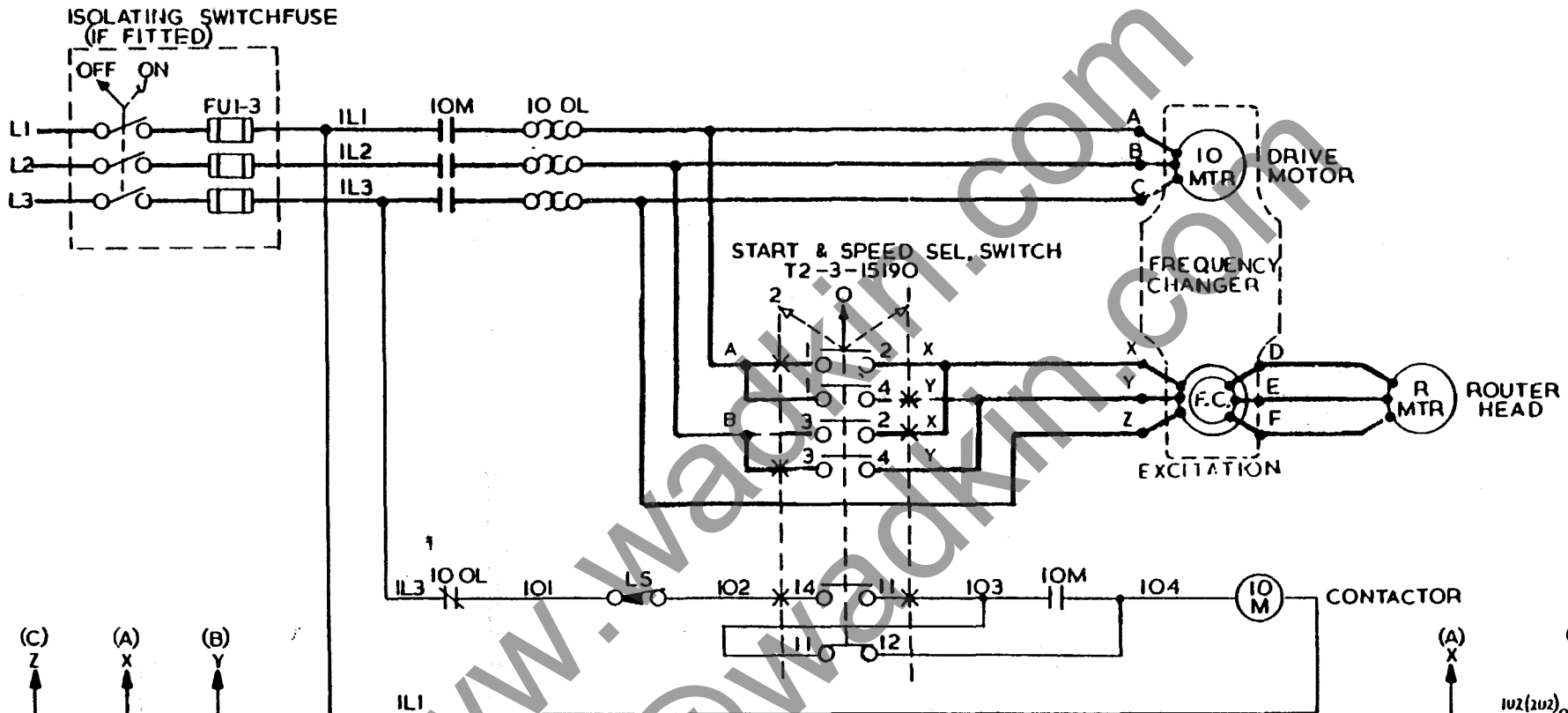

DRIVE MOTOR & EXCITATION WINDINGS, 60HZ

FOR DUAL VOLTAGE CHANGER, 60HZ

	LINKS ON DRIVE	LINKS ON CHANGER
HIGH	T14-T17, T15-T18, T16-T19	T4-T7, T5-T8, T6-T9
LOW	T11-T17, T12-T18, T13-T19, T14-T15-T16	T1-T7, T2-T8, T3-T9, T4-T5-T6

DRIVE:- A-T11, B-T12, C-T13.
 EXCITATION:- X-T1, Y-T2, Z-T3.
 OUTPUT:- D-M1, E-M2, F-M3.

FOR DUAL VOLTAGE CHANGER, 50HZ

	LINKS ON DRIVE	LINKS ON CHANGER
HIGH	2U2-2V2-2W2	IU2-IV2-IW2
LOW	2U1-2V2, 2V1-2W2, 2W1-2U2.	IU1-IV2, IV1-IW2, IW1-IU2.

DRIVE:- A-2U1, B-2V1, C-2W1.
 EXCITATION:- X-IU1, Y-IV1, Z-IW1
 OUTPUT:- D-K, E-L, F-M.

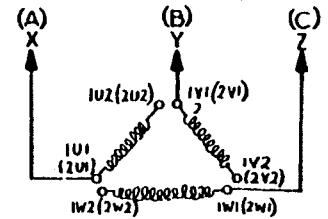

DRIVE MOTOR & EXCITATION WINDINGS 50HZ

SIMILAR TO

THIRD ANGLE PROJECTION

WADKIN LTD. LEICESTER

SURFACE FINISH
V - ROUGH M/C
∇∇ - FINISH M/C
∇∇∇ - ROUGH GRIND
∇∇∇∇ - FINISH GRIND

IMPERIAL LIMITS
FRACTIONS ± 1/32"
DECIMALS ± .005"
METRIC LIMITS
WHOLE NUMBERS - ± 1 M/M
DECIMALS - ± 0.1 M/M
BALL BEARING LIMITS SEE LIST

DATE	SIG.	D	C	B	A
ALT. No.					

24-5-78	50, 60 HZ DUAL VOLTAGE CONNECTIONS ADDED
---------	--

DATE 6-2-78	DRN. BY <i>ARK</i>
	CHKD. BY

DESCRIPTION
UR ROUTER WITH KLOCKNER SWITCH

QTY.	MATERIAL
PART No. D.2546	

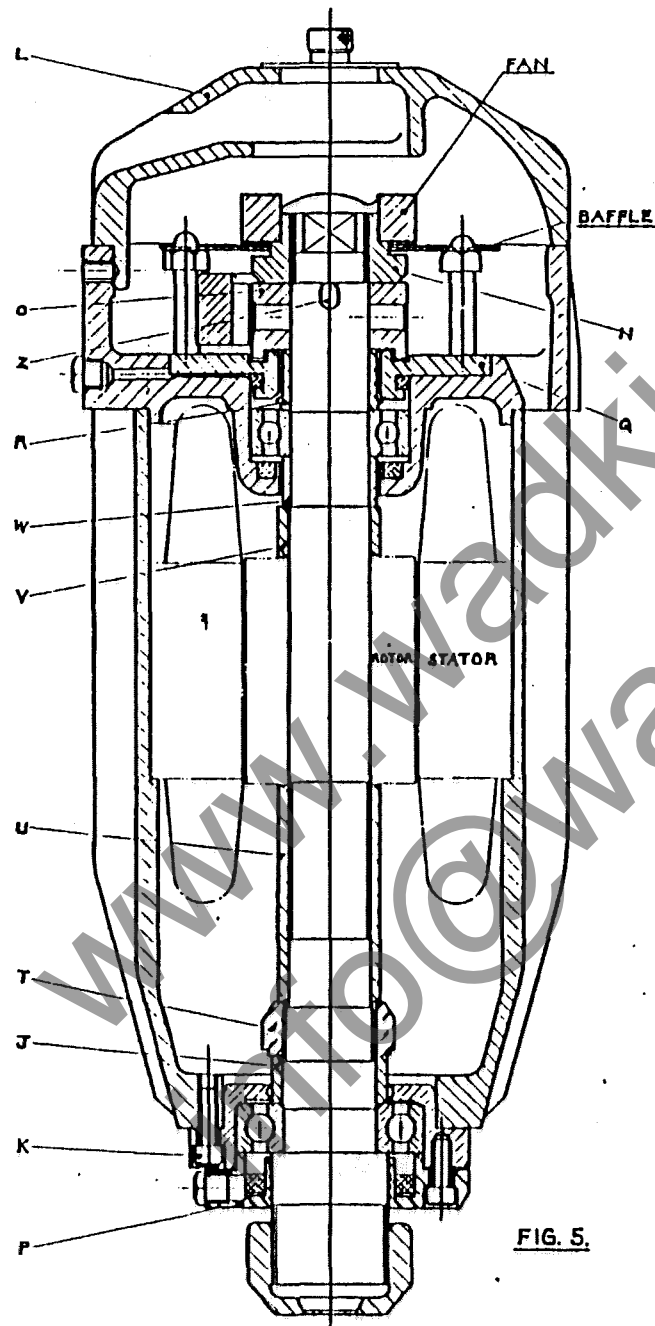

SECTIONAL DRAWING OF ROUTER HEAD.

FIG. 5.

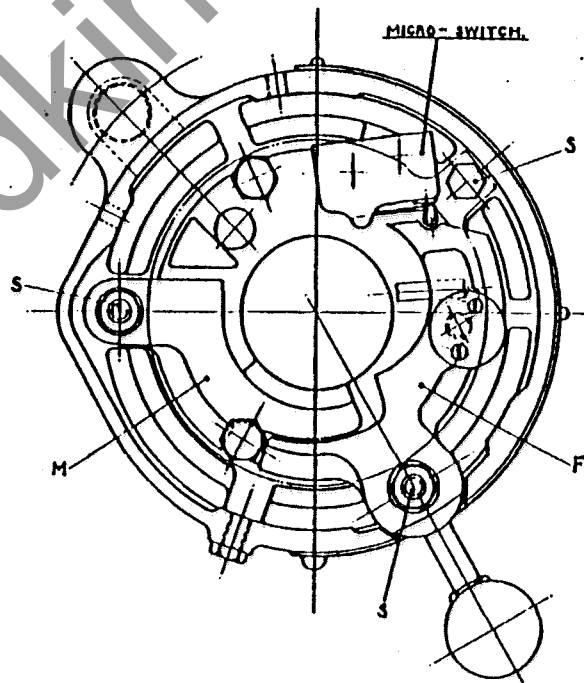

FIG. 5.

Wadkin OPERATING AND MAINTENANCE INSTRUCTIONS

TO DISMANTLE SPINDLE CARRY OUT THE FOLLOWING :-

1. Isolate machine.
2. Remove cover "L" (see Fig. 5).
3. Disconnect electrical leads and label accordingly.
4. Remove fan and baffle, nut "N" (left hand thread), lift off brake drum "O".
5. Remove keys "Z".
6. Remove collet and bottom cover "P".
7. Remove screws "K" securing bottom bearing housing.
8. Drive the spindle downwards by gentle blows from the top, when the complete spindle with rotor will emerge from the housing.
9. To remove the rotor, first lift off sleeves "V" and "W", use the screw jack provided as shown (Fig. 4) in order to avoid damage to the rotor and spindle.
10. **IMPORTANT:** Do not subject the rotor or bearings to hammer blows.
11. In removing lower bearing, take off sleeve "U", nut "T" (left hand thread) and sleeve "J".
12. In removing upper bearing, detach micro-switch with great care in order to avoid damage.
13. Remove spindle lock "F" and brake shoe "M".
14. Remove retaining cap "Q" and lift out sleeve "R".

Wadkin OPERATING AND MAINTENANCE INSTRUCTIONS

15. Remove the three studs "S" securing the top bearing housing.
16. Before reassembling spindle, thoroughly clean bearings and housings free of old lubricant and smear ball races with a little new lubricant. Renew all felt rings.
17. To assemble spindle, first fix lower bearing and housing, then sleeve "J", nut "T" and sleeve "U". Afterwards press on the rotor and collars "V" and "W". The spindle is now passed through the lower end housing and up through the motor casing. The lower bearing housing is now held in position by screws "K", cover "P" is afterwards fixed.
18. To reassemble upper bearing housing, first fix bearing and housing, secure housing by studs "S". Replace sleeve "R" and retaining cap "Q". Replace brake shoe "M" and spindle lock "F". Fix keys "Z" into position and replace brake drum "O", screw on nut "N₁" and lock.
19. To fix micro-switch in position. Care must be taken in order to avoid damage. Replace micro-switch in position but do not lock screws, operate spindle lock "F" in both positions, "lock and brake", ensuring that the micro-switch is operating correctly and no damage is likely to occur. This being completed the screws may be tightened.
20. Connect electrical leads.
21. Replace baffle and attach fan to spindle.
22. Replace top cover "L".

WADKIN OPERATING AND MAINTENANCE INSTRUCTIONS

ROUTER HEAD BEARINGS

Top Bearing :- Hoffmann N. 3420 25 mm. x 52 mm. x 15 mm.
Bottom Bearing :- Hoffmann N. 3243 30 mm. x 62 mm. x 16 mm.

Made specially for
Wadkin Ltd. from
whom replacements
should be obtained.

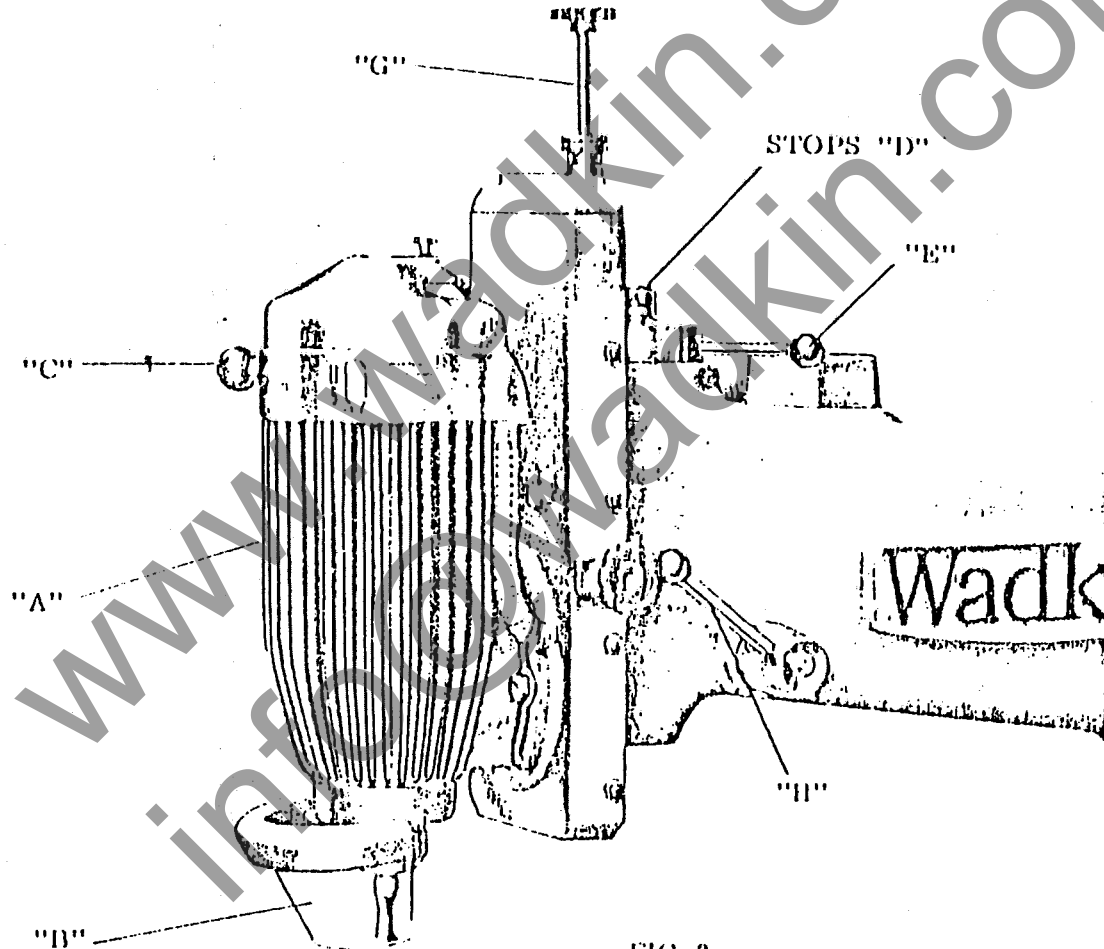

FIG. 3.

LIGHT HIGH SPEED ROUTER TYPE UR/B.

PRINCIPAL DIMENSIONS AND CAPACITIES:-

Centre of cutter spindle to inside of body frame	24in.	610 mm.
Maximum distance between table and chuck	11in.	280 mm.
Chuck will take cutter shanks up to 9/16in. diameter		
Total travel of cutter spindle	4in.	100 mm.
Minimum distance between table and chuck	1in.	25 mm.
Size of standard table	30in. x 27.1/2in.	760 x 700 mm.
Width of each table extension wing	10in.	255 mm.
Raising and lowering movement of table	6in.	150 mm.
Minimum height of table from floor	33in.	840 mm.
Spindle speeds in r.p.m. :- for 50 cycles	10,000 and 20,000	10,000 and 20,000
for 60 cycles	10,000 and 20,000	10,000 and 20,000
Floor space, with standard table	30in. x 43in.	760 x 1090 mm.
Overall height of machine	65.1/4in.	1650 mm.
Output of motor (intermittent rating)	6.7/4.0KW(9/5.5HP)	6.7/4.0KW(9/5.5HP)
Net weight with standard table	784 lb.	355 kg.
Gross weight with standard table	972 lb.	445 kg.
Shipping dimensions	85 cu.ft	2.40 cu.m.

Details included with machine :

Head motor and control gear all fully wired. Cutter guard.

Three Double-ended Guide Pins :-

3/16in.(5 mm.) diameter and 1/4in.(6 mm.) diameter

5/16in.(8 mm.) diameter and 3/8in.(10 mm.) diameter

7/16in.(12 mm.) diameter and 1/2in.(14 mm.) diameter

Two Guide Rollers :

3/4in.(20mm.) diameter to fit 3/8in.(12 mm.) diameter pin.

5/8in.(18mm.) diameter to fit 3/8in.(12 mm.) diameter pin.

One set of collets, set of spanners, oil gun.

A full range of cutter equipment is available for mounting direct in the spindle collet. Additionally, a range of eccentric chucks is available together with a full range of suitable cutters for eccentric operation.

Other sizes of guide pins including taper and graded undersized pins to compensate for cutter grinding are available.

Wadkin Ltd., Green Lane Works, Leicester LE5 4PF

Telephone: 0533 769111

Cables: Woodworker Leicester

Telex: 34646 (Wadkin Leicester).

Telephone: 01 - 9027714

Telex: 262210

London Office: York House, Empire Way, Wembley, Middlesex. HA9 0PA

UR/B MEDIUM DUTY BELT DRIVEN ROUTER

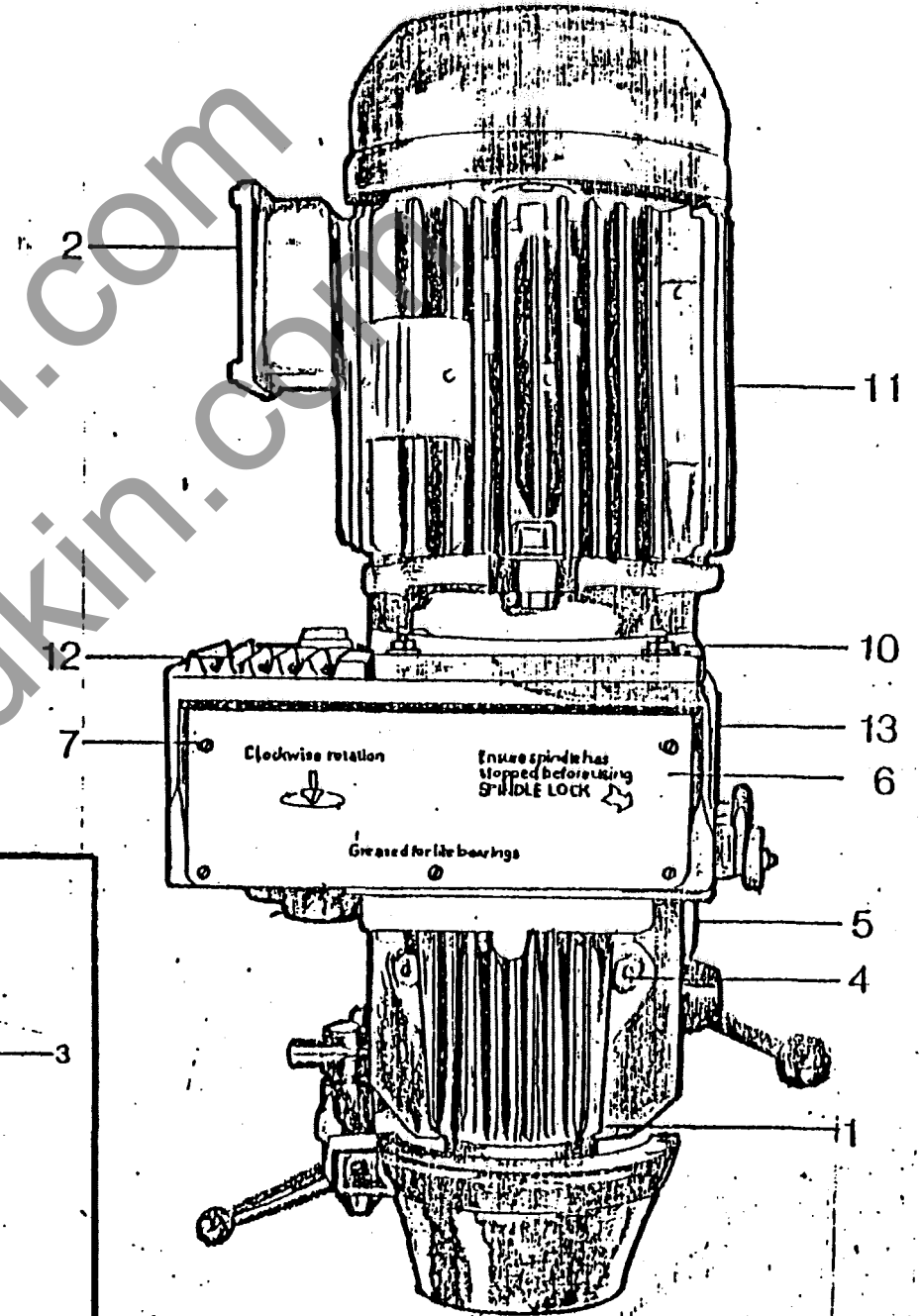
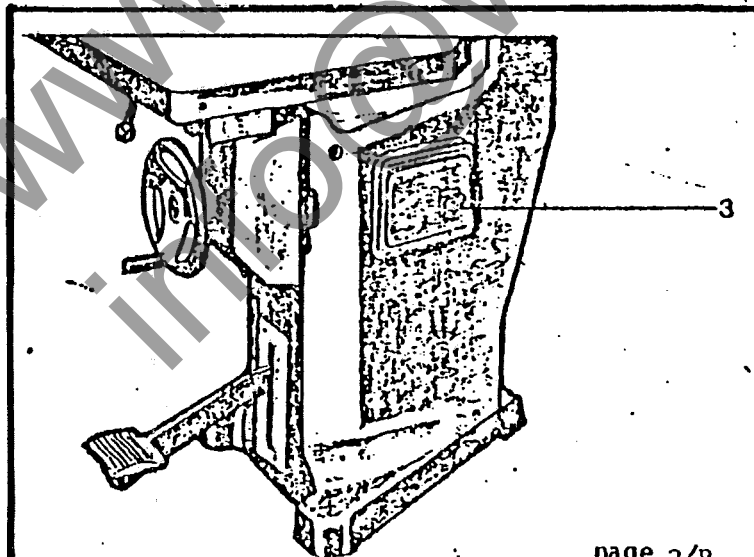
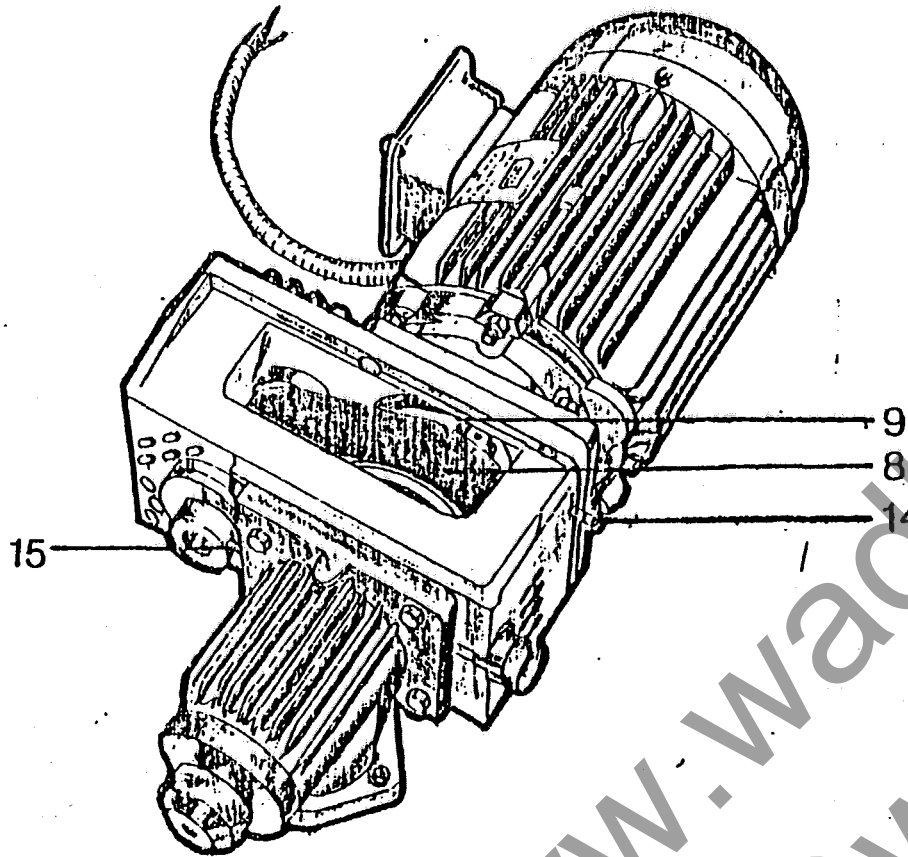

UR/B MEDIUM DUTY BELT DRIVE ROUTER

CHANGING THE HEAD MOTOR BELTS

In the event of the necessity arising wherein the Polyvee Belts require changing - Proceed as follows:-
In order to facilitate the procedure it may be necessary to remove the Router Head (1) completely away from the machine, in any case whether or not the Head is removed from the machine the following steps must be taken.

- 1) Disconnect the incoming leads at the motor terminal box (2) having ascertained that the "mains" are switched off at the machine disconnect switch (3).
- 2) In the event of finding it necessary to remove the Head motor (1) from the machine it will only be necessary to release the two Nuts (4) from the Router Head Slide (5) and slide the complete Head Motor away from the Slide Pivot hole. Place the complete Head Motor on a table or workbench.
- 3) Remove Cover (6) by removing the five Screws (7) this will reveal the two Belts (8) and (9).
- 4) Remove the four Nuts (10) holding the Motor (11) on the Router Body Lid (12) and remove the Motor bodily from Router Head Body (13).
- 5) Release (unfasten) socket type Grubscrew (14) to remove tension from the Belt. Unfasten the five Cap Screws to remove Router Body Lid (12), the Pulley Belt (8) is now accessible and can be released from the two Drive Pulleys.
- 6) Release (unfasten) Socket type Grubscrew (15) to remove tension from lower Belt (9). This will facilitate the removal of the Lower Belt from the Layshaft.

Having changed the Belts - the Head can be re-assembled by reversing the above procedures.

UR/B MEDIUM DUTY BELT DRIVE ROUTER - PARTS LIST

Ref No:	Part No:	Description	No.Off
1	K13 08 009	"BROOK" D100LBC motor 3.3/2.6KW(4.4/3.5HP)continuous 6.7/4.0KW(9/5.5HP) 5 min.rated class 'F' insulation	1
1a	K13 08 321	- Ditto - 380 volts 3 phase 50 hertz. 3000/1500 rpm.	1
1b	K13 08 322	- Ditto - 415 volts 3 phase 50 hertz. 3000/1500 rpm.	1
1c	K13 08 323	- Ditto - 230 volts 3 phase 60 hertz. 3600/1800 rpm.	1
1d	K13 08 324	- Ditto - 460 volts 3 phase 60 hertz. 3600/1800 rpm.	1
1e	K13 08 325	- Ditto - 550/600 volts 3 phase 60 hertz. 3600/1800 rpm.	1
2	UX 1103	Motor mounting plate	1
3	UX 1102	Router Body Lid	1
4	UX 1100	Router Head Body	1
5	UX 1077	Cover Plate	1
6	UX 1112	Bearing Retainer Washers	2
7	UX 1110	Layshaft End Support Cap	1
8	K06 01 192	Layshaft Bearings - SKF 6203 2RS	2
9	UX 1108	Layshaft Pulley	1
10	K30 78 143	Polyvee Belt - 190 J 16 - 50 hertz.	1
10a	K30 78 318	Polyvee Belt - 180 J 16 - 60 hertz.	1
11	UX 1105	Layshaft	1
12	UX 1107	Endcap for Layshaft Pulley	1
13	UX 1106	Endcap for Layshaft	1
14	K30 78 144	Polyvee Belt - 180 J 10 - 50 hertz.	1
15	K30 77 184	Taper Lock Bush - 1610 - 28mm. bore x 8mm. keyway.	1
16	UX 1075	Polyvee Pulley - 16 J 4.50 - 50 hertz.	1
16a	UX 1076	Polyvee Pulley - 16 J 4.50 - 60 hertz.	1

UR/B MEDIUM DUTY BELT DRIVE ROUTER - PARTS LIST CONTD.

Ref No:	Part No:	Description	No. Of
17	UX 1116	Spindle Pulley Retainer Washer	1
18	UX 1111	Main Spindle Pulley	1
19	K06 20 102	Main Spindle Bearings - RHP 1/P6206	2
20	UX 1114	Spacing Sleeve	1
21	UX 1109	Cutter Spindle	1
22	LS 139	Cutter Spindle Nut	1
23	UX 1115	Endcap for Bottom Main Spindle Housing	1
24	UX 1101	Main Spindle Housing	1
25	UX 1121	Adjuster Bolt	4
26	K05 29 156	Pegs	2
27	UX 1119	Plunger Bar	1
28	K30 73 836	Plunger Spring * ENTEX 51	1
29	UX 1118	Plunger Location Cap	1
30	UX 1122	Pin for Plunger Bar Knob - for UX 1117	1
31	UX 1117	Knob for Plunger Bar	1
32	* UX 1091	Screwed dowel	2
33	* UX 1315	Screwed dowel	1
34	* UX 1312	Nylon dust shield	1

* not shown

NOTE: For Router Cutters and Accessories
Refer to Wadkin Tooling Brochure
Section 'J' Ref.No:1269 3M/C/2/77

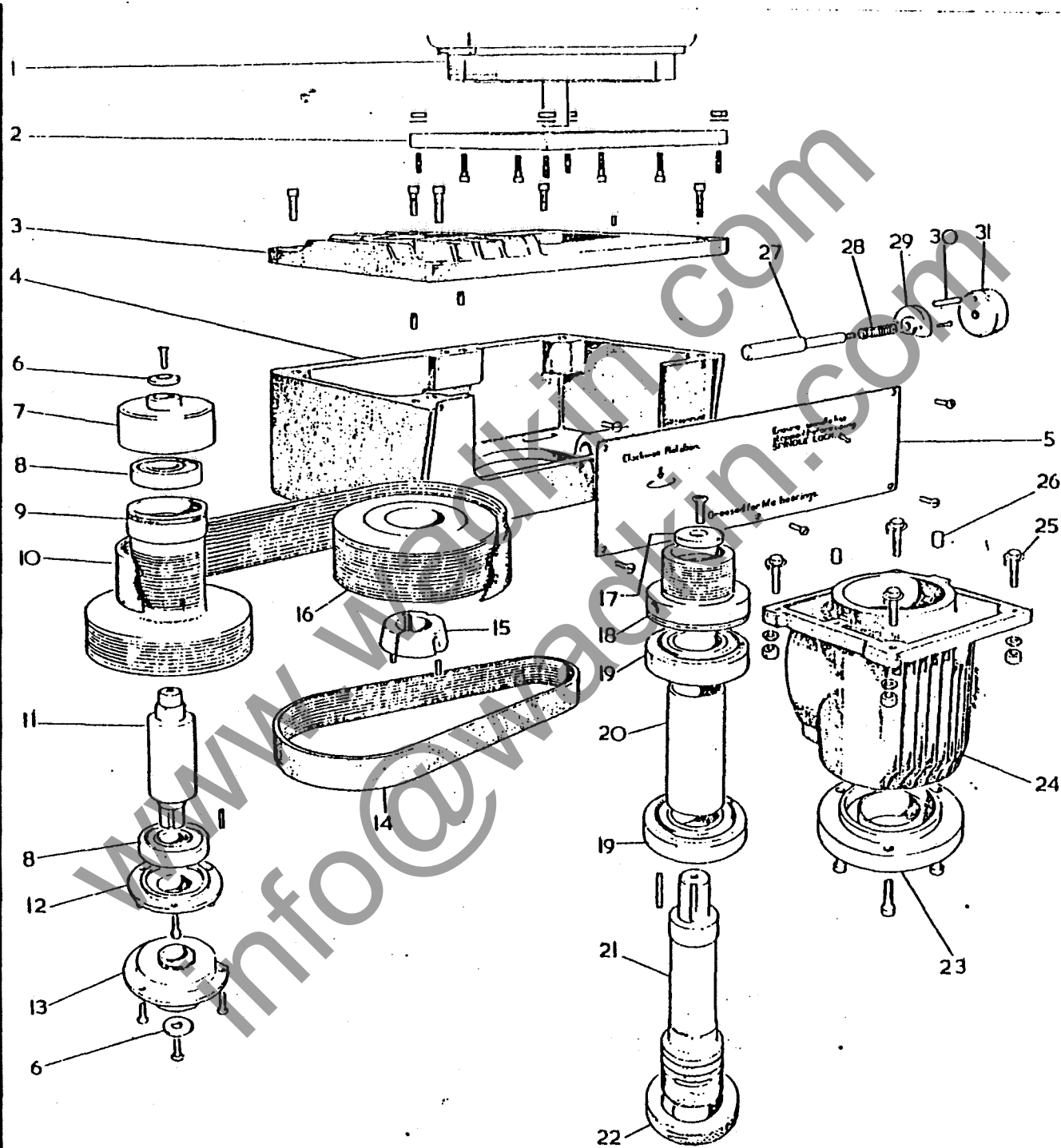

EXPLODED VIEW OF IIR/B. ROUTER HEAD

INSTALLATION

The machine is despatched from the Works with all bright surfaces greased to prevent rusting. This must be removed by applying a cloth damped with paraffin or turpentine.

FOUNDATIONS

Three $\frac{1}{2}$ " diameter foundation bolts must be used to bolt machine down to the floor. Foundation bolts are not supplied by Wadkin Ltd. unless specially ordered. "Rag" type holding down bolts may be used. If mill floor consists of from 4" to 6" solid concrete no special foundation is necessary. Cut out in concrete 4" to 6" square holes and fill in and grout with liquid cement after machine has been carefully levelled.

ELECTRICAL CONNECTIONS

See Pages 7/F for Frequency Head M/Cs, 7/B for Belt Head M/Cs for details and connection diagrams.

IMPORTANT :- The frequency changer must be bolted down, placed at any convenient position on the mill floor. Make sure that the surface is level and smooth to enable the frequency changer to be readily bolted down. (NB. Frequency changers are not fitted to belt head machines.)

Alignment of Table Pin to Spindle. A Setting Arbor is supplied for checking this alignment. The table is not dowelled to the vertical slide, so that it can be reset from time to time with the head.

Fit the setting arbor in the spindle and lower head to table. Now slacken 4 screws securing table to vertical slide and float table horizontally until the arbor in spindle enters pin hole in table. Retighten table securing screws, and remove arbor from spindle.

LIGHT HIGH SPEED ROUTER TYPE UR.

PRINCIPAL DIMENSIONS AND CAPACITIES :-

Centre of cutter spindle to inside of body frame	24"	610 mm.
Maximum distance between table and chuck	11"	280 mm.
Chuck will take cutter shanks up to 9/16" diameter		
Total travel of cutter spindle	4"	100 mm.
Minimum distance between table and chuck	1"	25 mm.
Size of standard table	30" x 27½"	760 x 700 mm.
Width of each table extension wing	10"	255 mm.
Raising and lowering movement of table	6"	150 mm.
Minimum height of table from floor	33"	840 mm.
Spindle speeds in r. p. m. :- for 50 cycles	18,000 and 24,000	18,000 and 24,000
for 60 cycles	18,000 and 25,000	18,000 and 25,000
Alternative speeds available to special order :- for 50 cycles	12,000 and 18,000	12,000 and 18,000
for 60 cycles	10,800 and 18,000	10,800 and 18,000
Floor space, excluding frequency changer, with standard table	30" x 43"	760 x 1090 mm.
Floor space of frequency changer	28½" x 13¼"	725 x 335 mm.
Overall height of machine	65¼"	1650 mm.
Horsepower of motor	2 h. p. at 18,000 r.p.m. 3 h. p. at 24,000 r.p.m.	2 h. p. at 18,000 r.p.m. 3 h. p. at 24,000 r.p.m.
Net weight with standard table including frequency changer	700 lb.	315 kg.
Gross weight with standard table including frequency changer	870 lb.	394 kg.
Shipping dimensions	85 cu. ft.	2.40 cu. m.
Code Word. (Add particulars of electric supply)	Uarer	Uarer

Details included with machine :

Head motor, frequency changer and control gear all fully wired. Cutter guard.

Three Double-ended Guide Pins :-

3/16" (or 5 mm.) diameter and ¼" (or 6 mm.) diameter
 5/16" (or 8 mm.) diameter and ⅜" (or 10 mm.) diameter
 7/16" (or 12 mm.) diameter and ½" (or 14 mm.) diameter

Two Guide Rollers :

¾" (or 20 mm.) diameter to fit ⅜" (or 12 mm.) diameter pin.
 ⅝" (or 18 mm.) diameter to fit ⅜" (or 12 mm.) diameter pin.

One set of collets, set of spanners, oil gun.

A full range of cutter equipment is available for mounting direct in the spindle collet. Additionally, a range of eccentric chucks is available together with a full range of suitable cutters for eccentric operation.

Other sizes of guide pins including taper and graded undersized pins to compensate for cutter grinding are available.

INSTALLATION

The machine is despatched from the Works with all bright surfaces greased to prevent rusting. This must be removed by applying a cloth damped with paraffin or turpentine.

FOUNDATIONS

Three $\frac{5}{8}$ " diameter foundation bolts must be used to bolt machine down to the floor. Foundation bolts are not supplied by Wadkin Ltd. unless specially ordered. "Rag" type holding down bolts may be used. If mill floor consists of from 4" to 6" solid concrete no special foundation is necessary. Cut out in concrete 4" to 6" square holes and fill in and grout with liquid cement after machine has been carefully levelled.

ELECTRICAL CONNECTIONS

See Page 65 for details and connection diagram.

IMPORTANT :- The frequency changer must be bolted down, placed at any convenient position on the mill floor. Make sure that the surface is level and smooth to enable the frequency changer to be readily bolted down.

Alignment of Table Pin to Spindle. A Setting Arbor is supplied for checking this alignment. The table is not dowelled to the vertical slide, so that it can be reset from time to time with the head.

Fit the setting arbor in the spindle and lower head to table. Now slacken 4 screws securing table to vertical slide and float table horizontally until the arbor in spindle enters pin hole in table. Retighten table securing screws, and remove arbor from spindle.

CANTING OF THE HEAD CAN BE
OBTAINED 90° EITHER SIDE OF
THE VERTICAL.

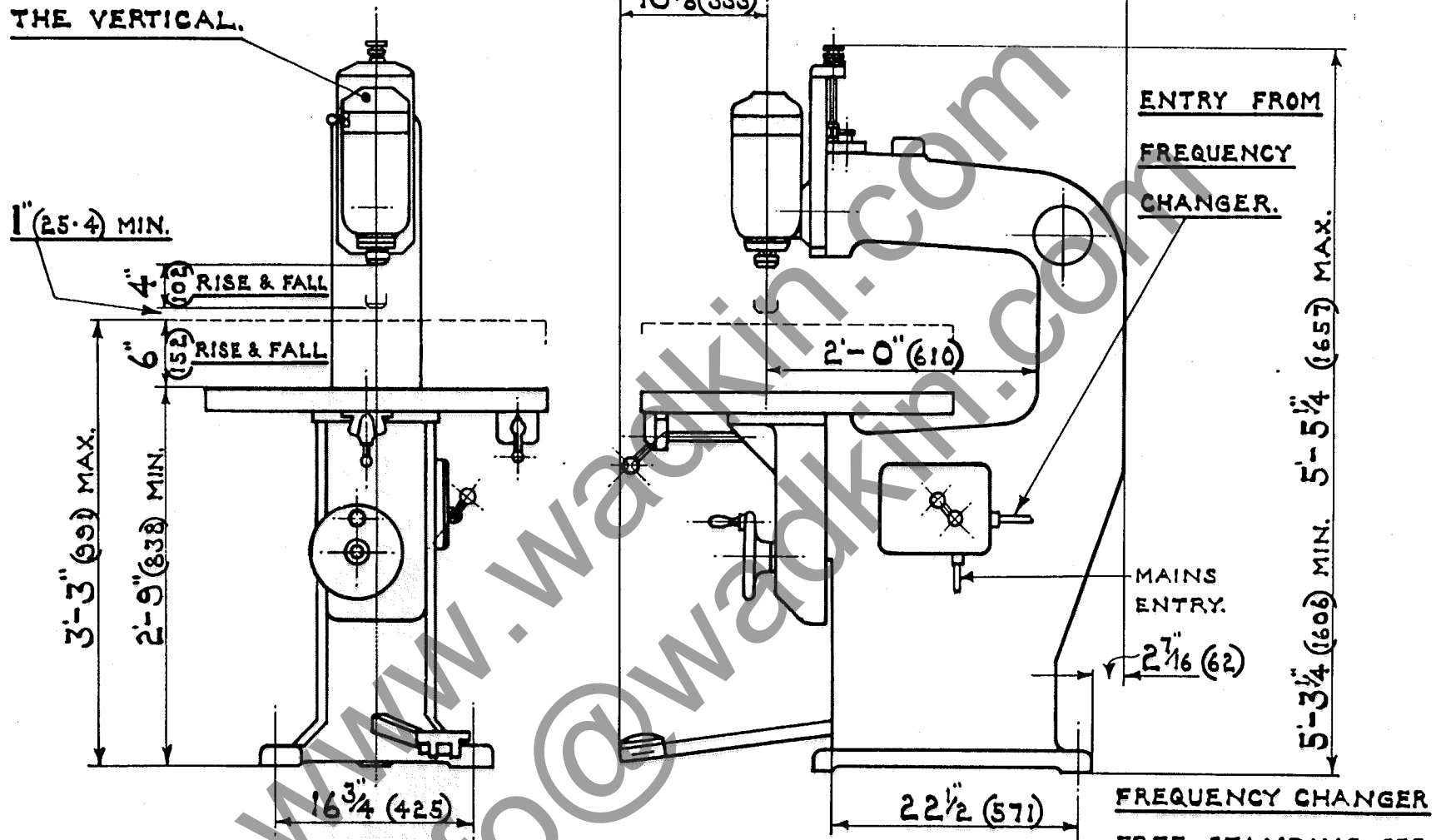

LIGHT HIGH SPEED ROUTER-TYPE-UR.

DIMENSIONS IN FT., INS., AND MILLIMETRES.

FREQUENCY CHANGER
FREE STANDING SEE
DRG. UR 13.

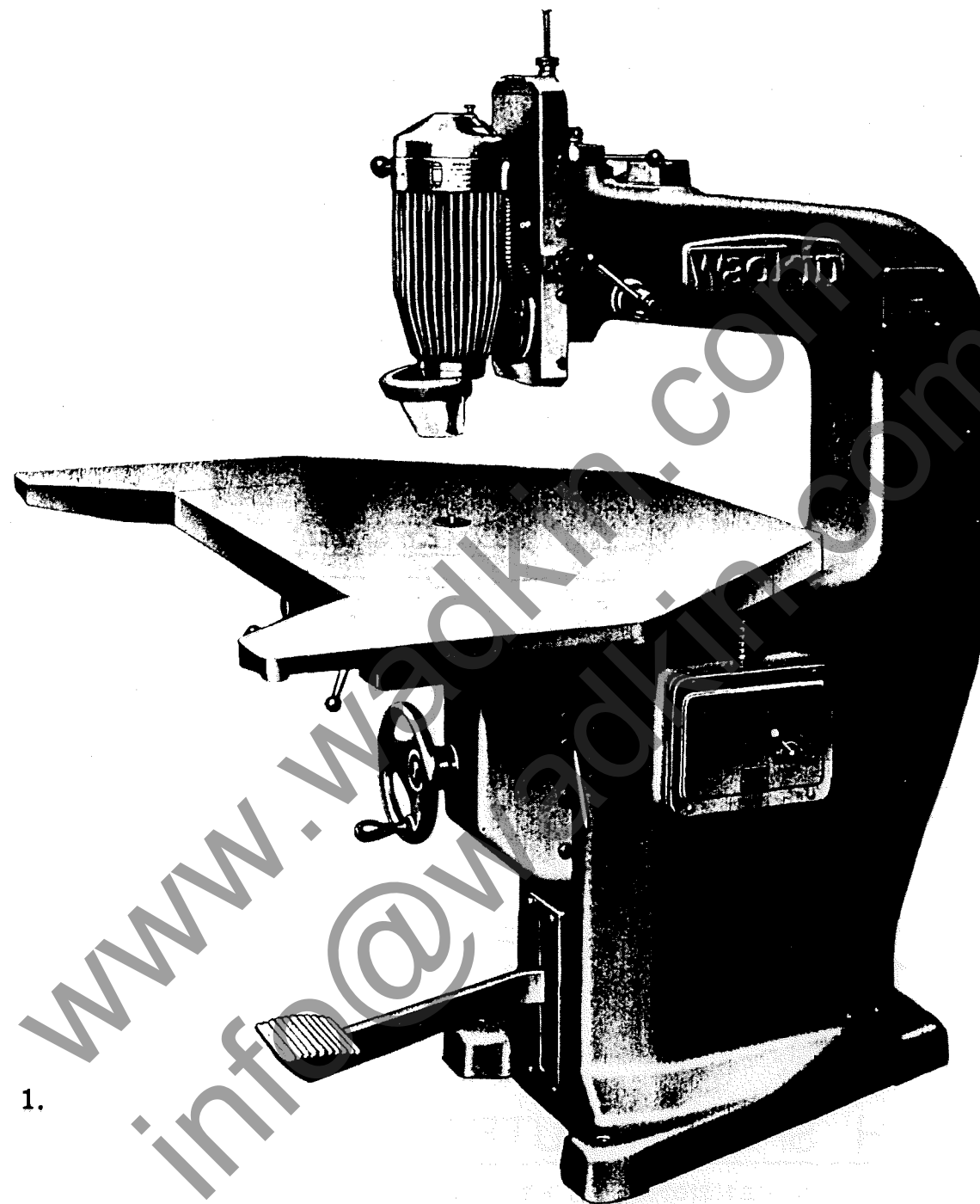

FIG. 1.

LUBRICATION

Points 'A' - Ball bearings and head slide and handwheel.
Give one depression of oil gun daily using Wadkin Grade L. 1. oil.

Points 'B' - Table slide. Lubricate from oil gun daily using light oil.

2 Points on Frequency Changer. Ball bearings. Give one to two depressions of grease gun every three months using Wadkin Grade L. 6. grease.

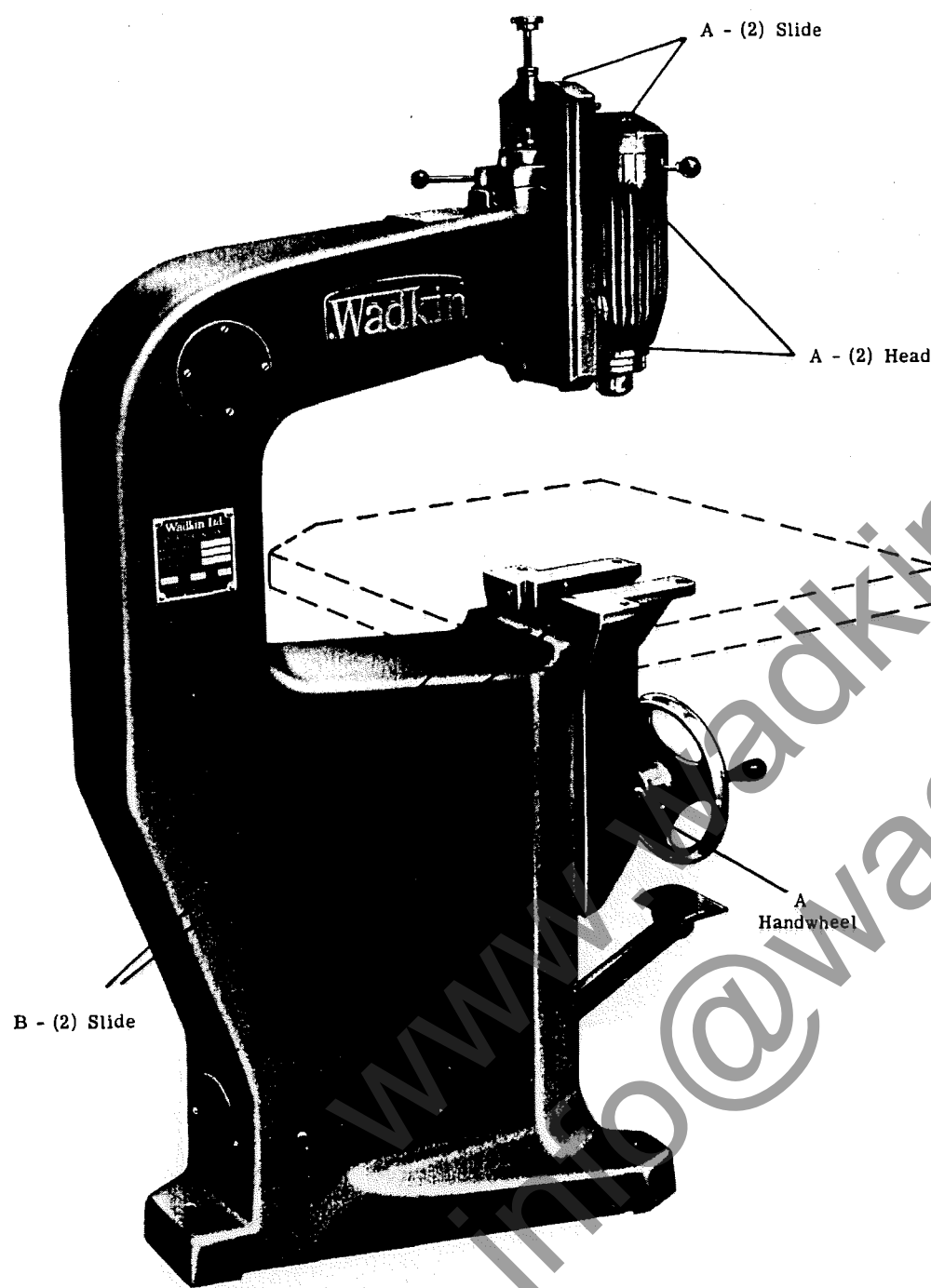

EQUIVALENT LUBRICANTS		
Wadkin Grade and Type	Oil Grade L. 1.	Grease Grade L. 6.
Mobil Oil Co.	D. T. E. Oil Light	MOBILUX Grease No. 2
Shell Mex & B. P. Ltd.	VITREA Oil 27	ALVANIA Grease No. 3
Castrol Ltd.	HYSPIN 70	SPHEEROL S

FIG. 2

ROUTER HEAD BEARINGS

Top Bearing :- Hoffmann N. 3420 25 mm. x 52 mm. x 15 mm.
Bottom Bearing :- Hoffmann N. 3243 30 mm. x 62 mm. x 16 mm.

Made specially for
Wadkin Ltd. from
whom replacements
should be obtained.

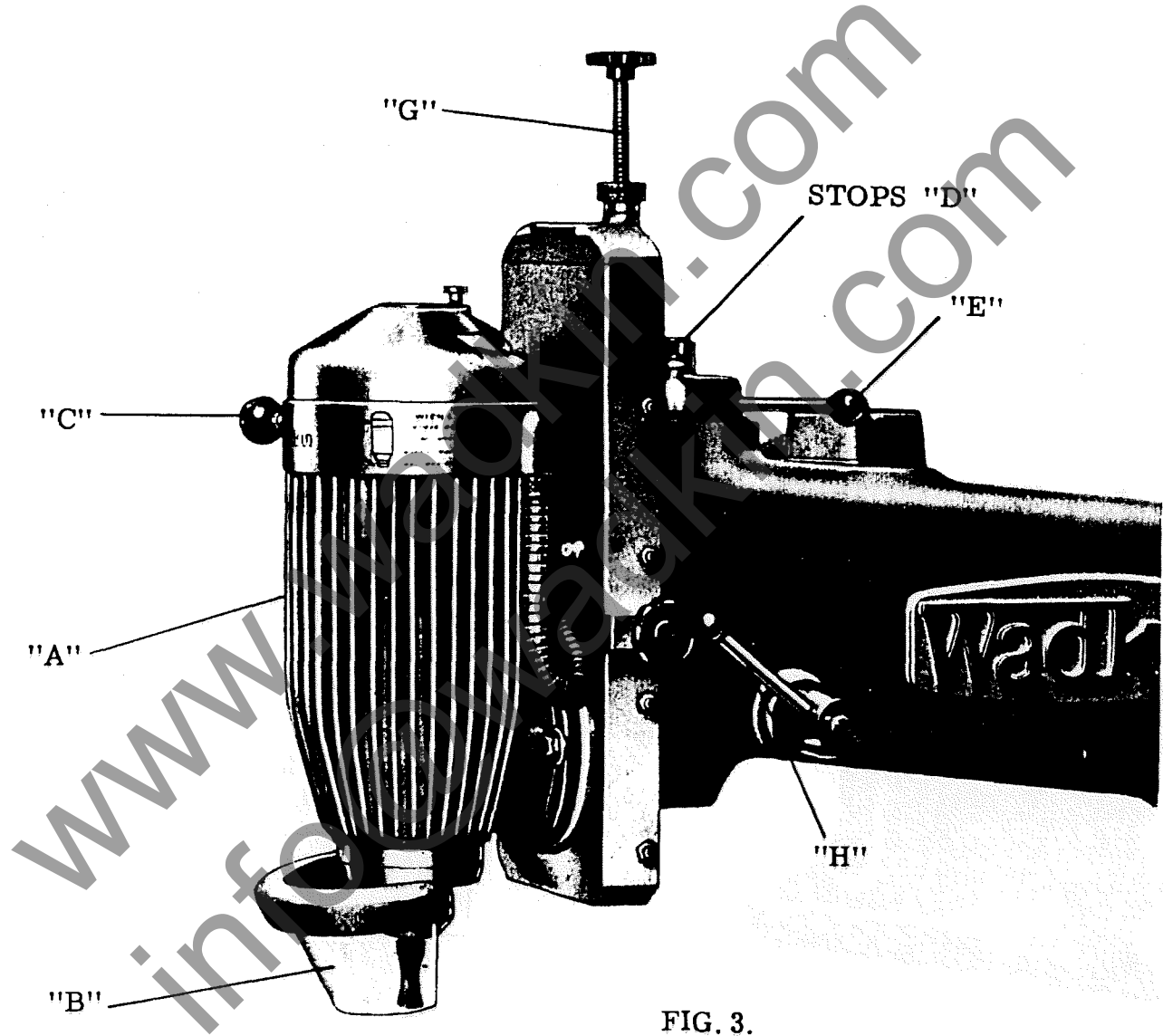

FIG. 3.

THE ROUTER HEAD (SHOWN IN SECTION ON PAGE 8)

The cutterhead motor, Fig.3 is built directly onto a nickel chrome steel spindle which runs on precision high speed bearings. The transparent guard "B" which can be swung away for easy access to the cutter, gives full protection to the operator without obstructing his view of the job. A quick acting brake and also a spindle lock for use when cutter changing are incorporated. The brake is operated by pressing the knob "C" to the left automatically switching off the motor. The spindle lock is operated by pressing knob "C" to the right, after first applying the brake, and left to the neutral position to unlock. Care must be taken not to start the machine whilst the locking bar is in position.

MOVEMENT OF THE HEAD

The head is lifted out of the job by means of the foot lever. The travel of the head is limited by a range of three stops "D" which control the downward movement. Any one of these stops may be selected by means of the hand lever "E". A long stop screw "G" gives a wide range of movement to the head. The head may be held in the up position by hand lever "H".

HEAD WITH AIR OPERATED MOVEMENT - (SEE PAGE 7a)

The head is either raised OR lowered by the foot operated 2 position treadle switch.

To lower the head depress the front of the treadle and to raise the head depress the rear of the treadle.

A "HYDROCHECK" unit is fitted to give a controlled deceleration to the downward movement, the speed of which can be varied by setting the knob on the top of the "HYDROCHECK" to the calibrated scale.

The downward travel is limited by a range of three stops similar to the lever operated router head.

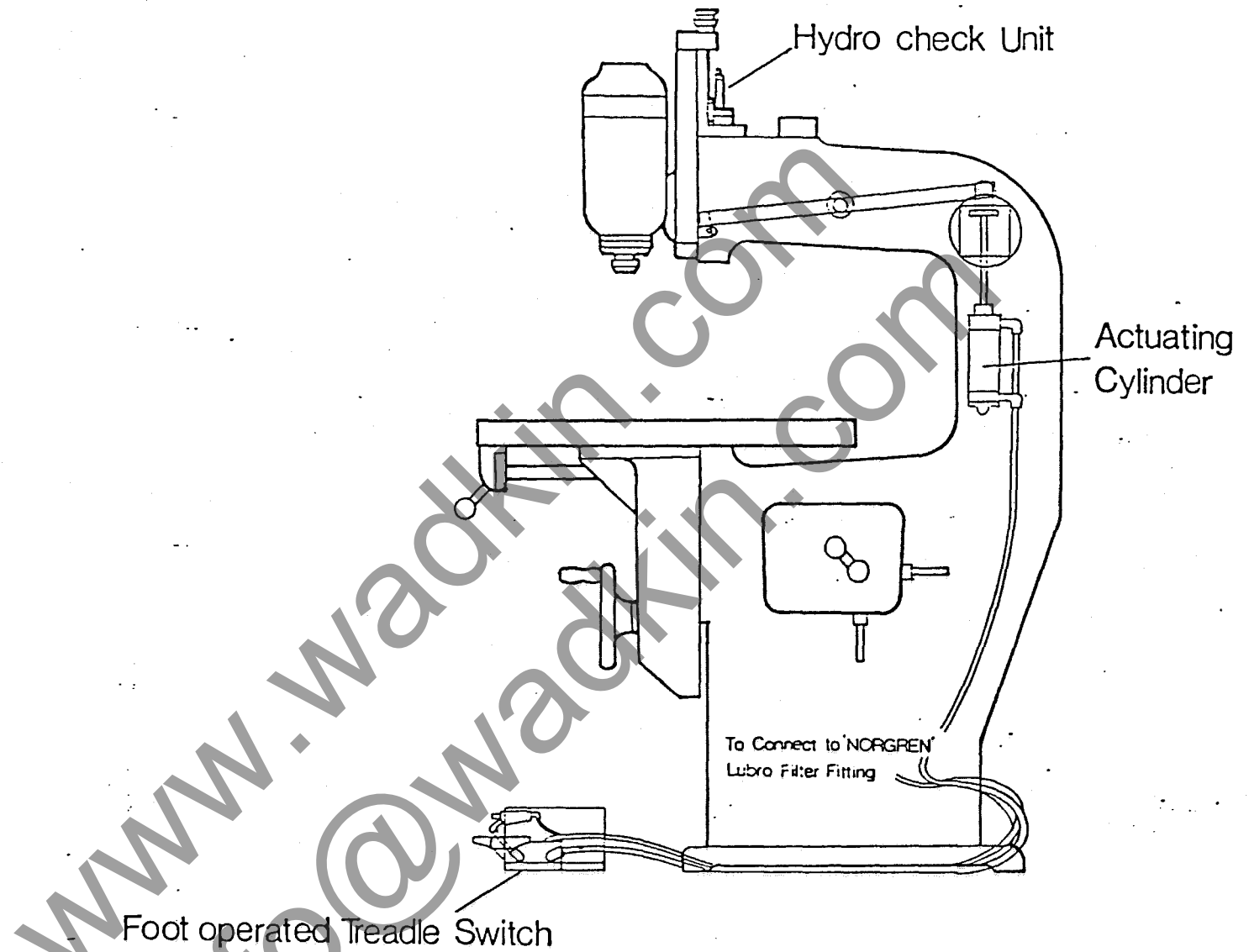

LIGHT HIGH SPEED ROUTER TYPE UR

LUBRICATION OF BEARINGS

The bearings are lubricated by a patented system of oil mist lubrication and therefore it is important to use the oil and to lubricate the bearings to instructions given on page 5. Since the introduction of our patented system, the special high speed ball bearings (which must be purchased from "WADKIN LTD") have given exceptional performance, but as no guarantee can be given against bearing failure which could be attributable to over lubrication OR other causes, it is recommended that the Head is returned to us for repair. We have a Service Department where the work is undertaken with the minimum delay.

Where machines are shipped abroad this service arrangement cannot economically be given. Under these circumstances a description of how to dismantle the Head is give on pages 9 and 10.

A device to assist with the removal of the ROTOR is included with export machines.

LOOSE END PLUG INSERTED IN
SPINDLE TO TAKE THRUST OF SCREW.



Fig. 4.

SCREW JACK FOR REMOVING ROTOR.

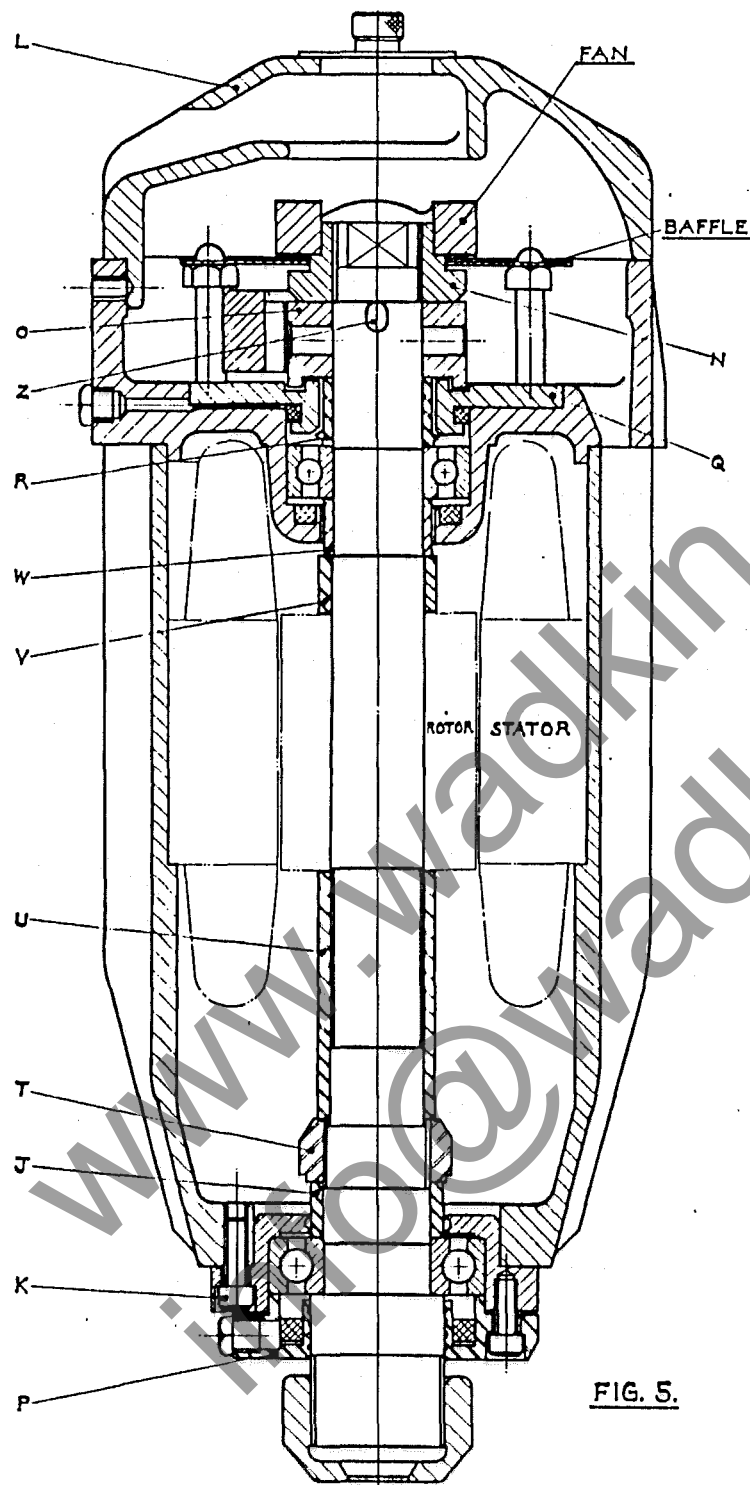
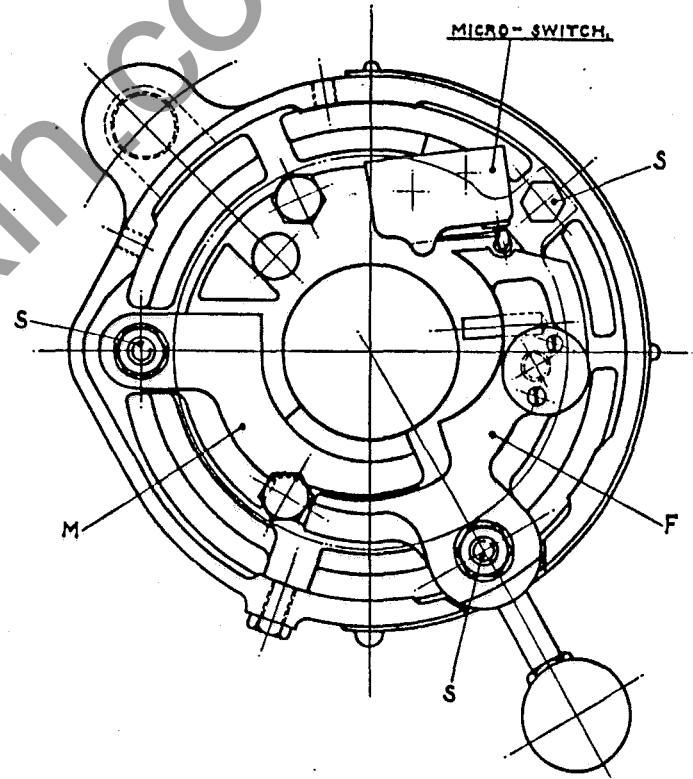

FIG. 5.

SECTIONAL DRAWING OF ROUTER HEAD.

FIG. 5.



TO DISMANTLE SPINDLE CARRY OUT THE FOLLOWING :-

1. Isolate machine.
2. Remove cover "L" (see Fig.5).
3. Disconnect electrical leads and label accordingly.
4. Remove fan and baffle, nut "N" (left hand thread), lift off brake drum "O".
5. Remove keys "Z".
6. Remove collet and bottom cover "P".
7. Remove screws "K" securing bottom bearing housing.
8. Drive the spindle downwards by gentle blows from the top, when the complete spindle with rotor will emerge from the housing.
9. To remove the rotor, first lift off sleeves "V" and "W", use the screw jack provided as shown (Fig.4) in order to avoid damage to the rotor and spindle.
10. **IMPORTANT :** Do not subject the rotor or bearings to hammer blows.
11. In removing lower bearing, take off sleeve "U", nut "T" (left hand thread) and sleeve "J".
12. In removing upper bearing, detach micro-switch with great care in order to avoid damage.
13. Remove spindle lock "F" and brake shoe "M".
14. Remove retaining cap "Q" and lift out sleeve "R".

15. Remove the three studs "S" securing the top bearing housing.
16. Before reassembling spindle, thoroughly clean bearings and housings free of old lubricant and smear ball races with a little new lubricant. Renew all felt rings.
17. To assemble spindle, first fix lower bearing and housing, then sleeve "J", nut "T" and sleeve "U". Afterwards press on the rotor and collars "V" and "W". The spindle is now passed through the lower end housing and up through the motor casing. The lower bearing housing is now held in position by screws "K", cover "P" is afterwards fixed.
18. To reassemble upper bearing housing, first fix bearing and housing, secure housing by studs "S". Replace sleeve "R" and retaining cap "Q". Replace brake shoe "M" and spindle lock "F". Fix keys "Z" into position and replace brake drum "O", screw on nut "N" and lock.
19. To fix micro-switch in position. Care must be taken in order to avoid damage. Replace micro-switch in position but do not lock screws, operate spindle lock "F" in both positions, "lock and brake", ensuring that the micro-switch is operating correctly and no damage is likely to occur. This being completed the screws may be tightened.
20. Connect electrical leads.
21. Replace baffle and attach fan to spindle.
22. Replace top cover "L".

TABLE.

The fixed table has a removable centre bung. Three holes are provided along each side of the table for securing side wing tables (additional to special order). These considerably increase the working area of the table.

FORMER OR GUIDE PIN.

The routing of all kinds of shaped work is done with jigs, the cutter reproducing the shape. A formed shape or template is attached to the underside of the jig and is worked round a pin projecting through the table as shown on page 14 and subsequent pages.

The pins are reversible in the table, each end being made a different size to correspond with the diameter of the cutter. The lever handle (see page 12) gives three heights of the pin above the table to allow for different depths of cut or sinking. To change the pins, slacken locking handle by the side of lever handle.

The following former pins and rollers can be supplied :-

Pins for Table (supplied with machine)	Rollers for both types of pin
3/16" - $\frac{1}{4}$ ") Double ended 5/16" - $\frac{3}{8}$ ") and 7/16" - $\frac{1}{2}$ ") Reversible	$\frac{5}{8}$ ", $\frac{3}{4}$ ", $\frac{7}{8}$ ", 1", $1\frac{1}{8}$ ", $1\frac{1}{4}$ ", $1\frac{3}{8}$ ", $1\frac{1}{2}$ " All rollers are arranged to fit the $\frac{3}{8}$ " size pins only.

Former pin in low position.

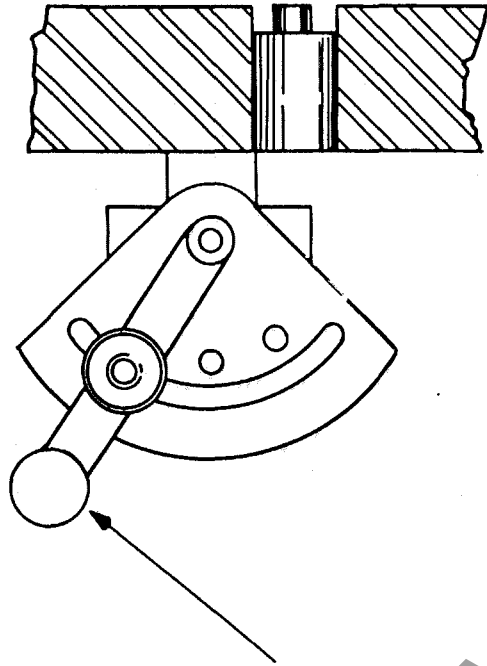

Former pin in mid position.

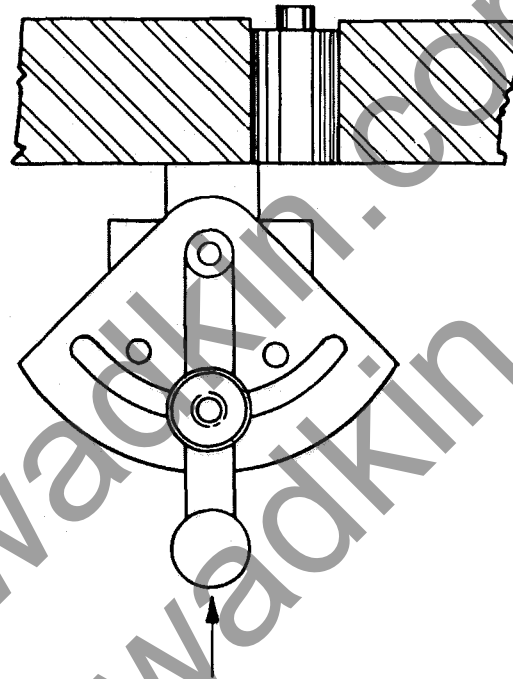

Former pin in high position.

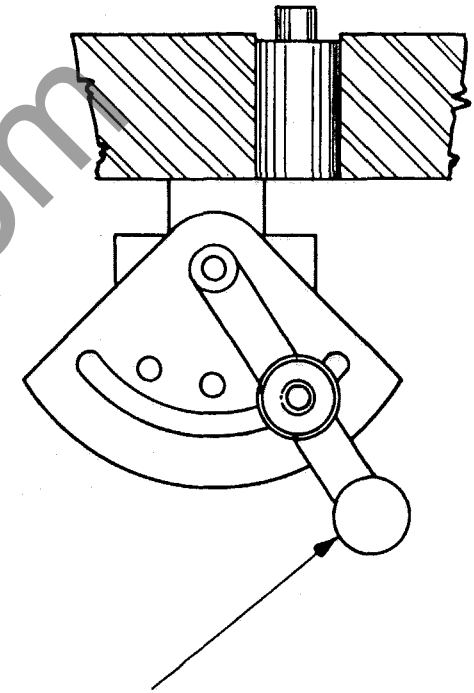

Lever handle for controlling rise and fall movement of former pin.

To allow for various thicknesses and position of templates on jigs also multiple templates, the former pin has three controlled positions.

THE BASIC PRINCIPLES OF ROUTING TO PROFILED SHAPES.

CUTTER

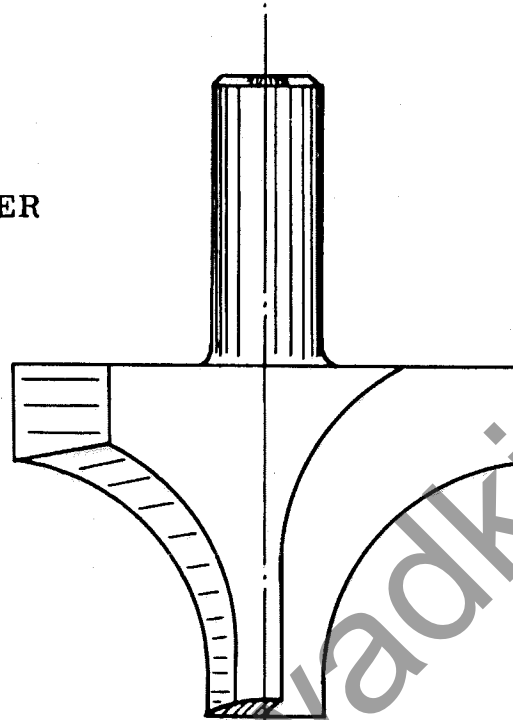

The component produced will then be correct in size and profile.

COMPONENT

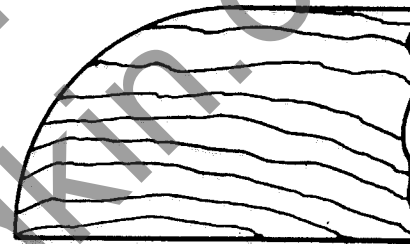

The smallest diameter of the router cutter and the diameter of the former pin should be the same.

FORMER PIN



TEMPLATE



The template should be the same profile and size as the component or article to be produced.

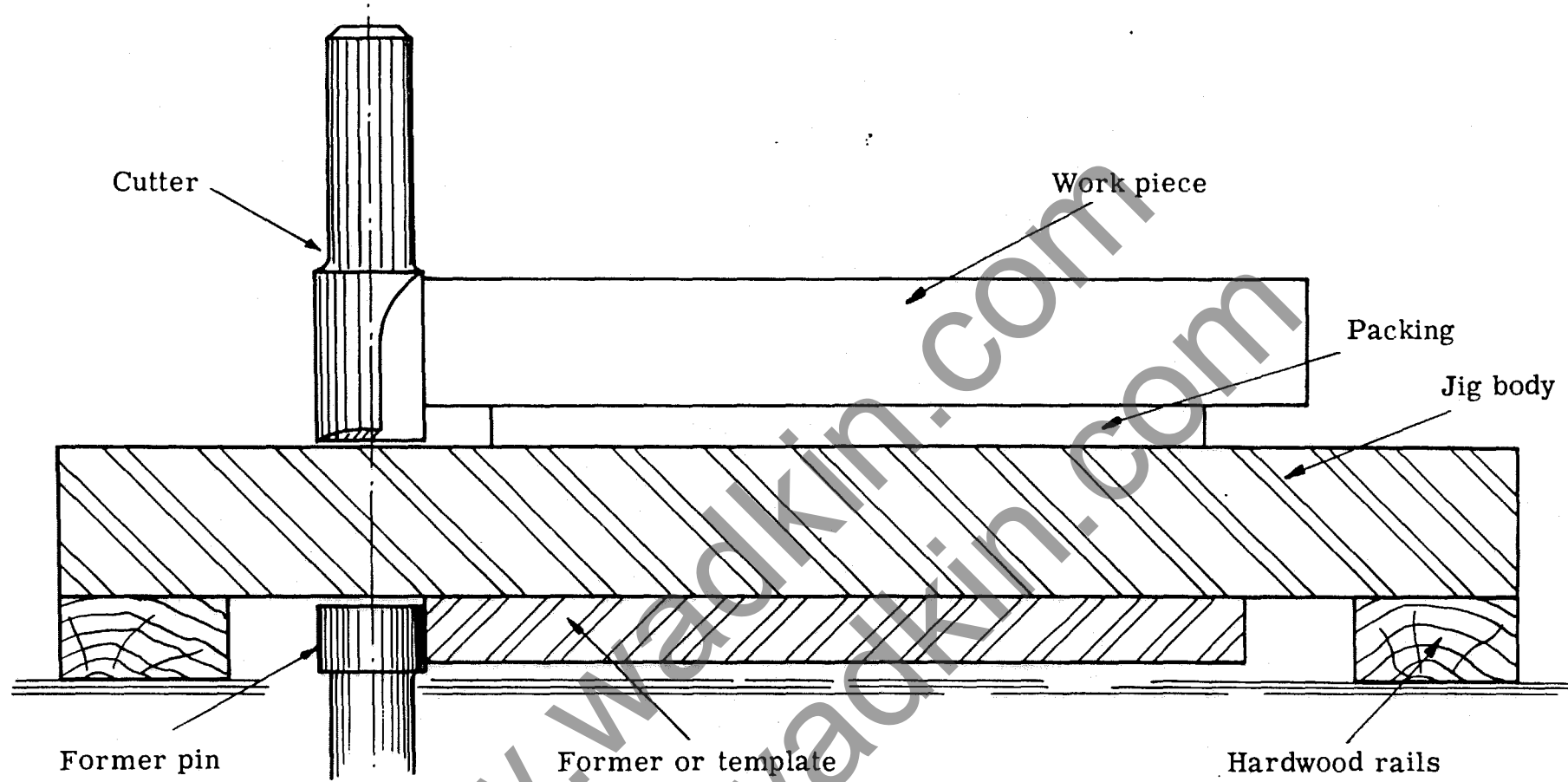

JIG FOR PROFILING

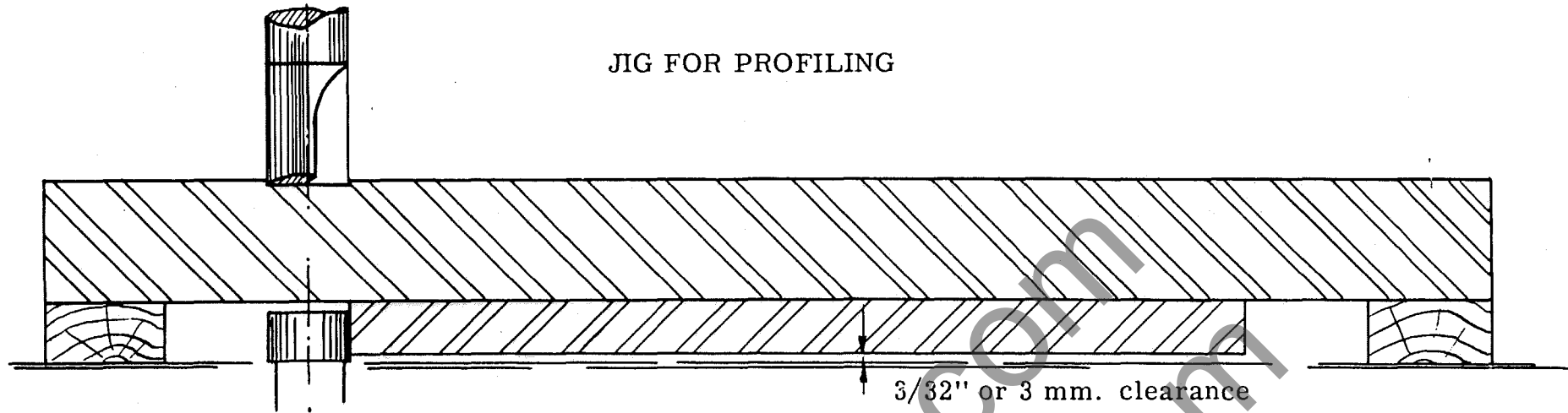

Fix hardwood rails to jig body and screw template in suitable position. It is advisable to have the jig 4" or 5" (100 mm. or 150 mm.) larger all round than the work piece. Fix rails and template, mark the surface of jig body by making a shallow cut with suitable size of cutter, tracing the shape of the template on the face of the jig. Cutter and former pin must be of same diameter.

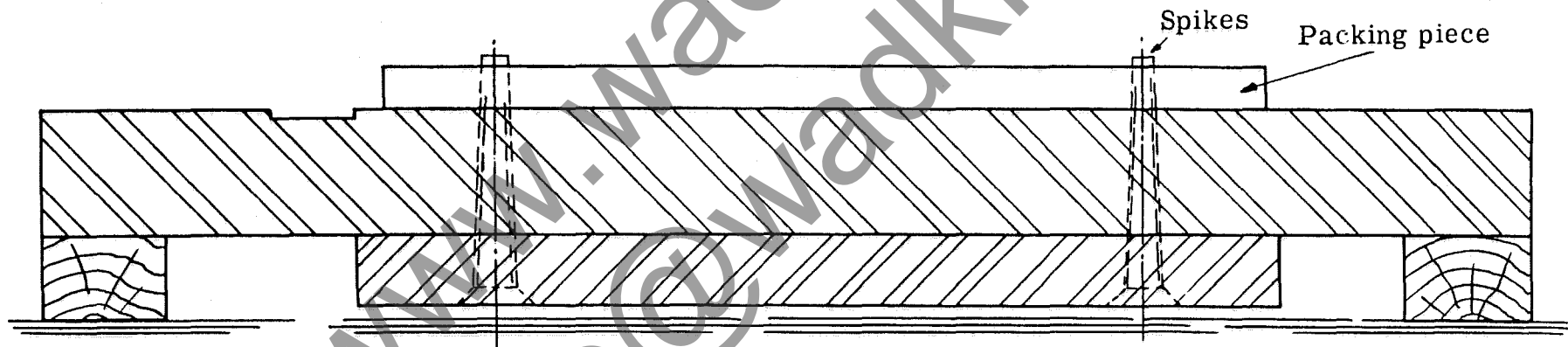

Having surface of jig correspondingly marked with the shape and position of template the packing piece can be fixed in position.

If holding spikes are required these can be fitted. Use wood screws of suitable length to project 3/32" (3 mm.) through packing piece. File screw ends to a chisel edge.

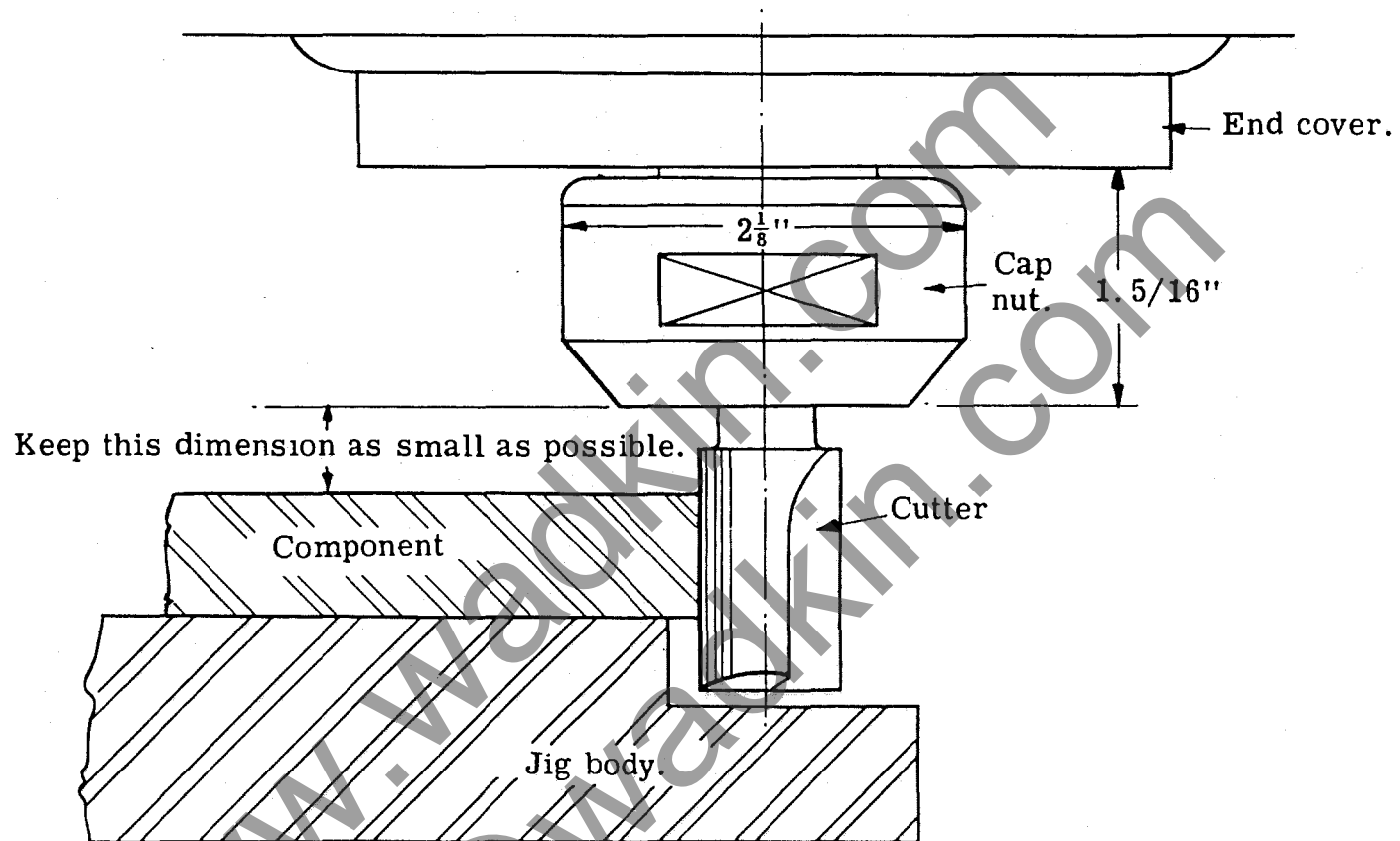

Always keep the top face of the component as near to the collet cap nut as possible.
 Any top cramping device must be low enough to clear the end cover of router head.

Jig for routing to shape curved components such as brush backs, etc.

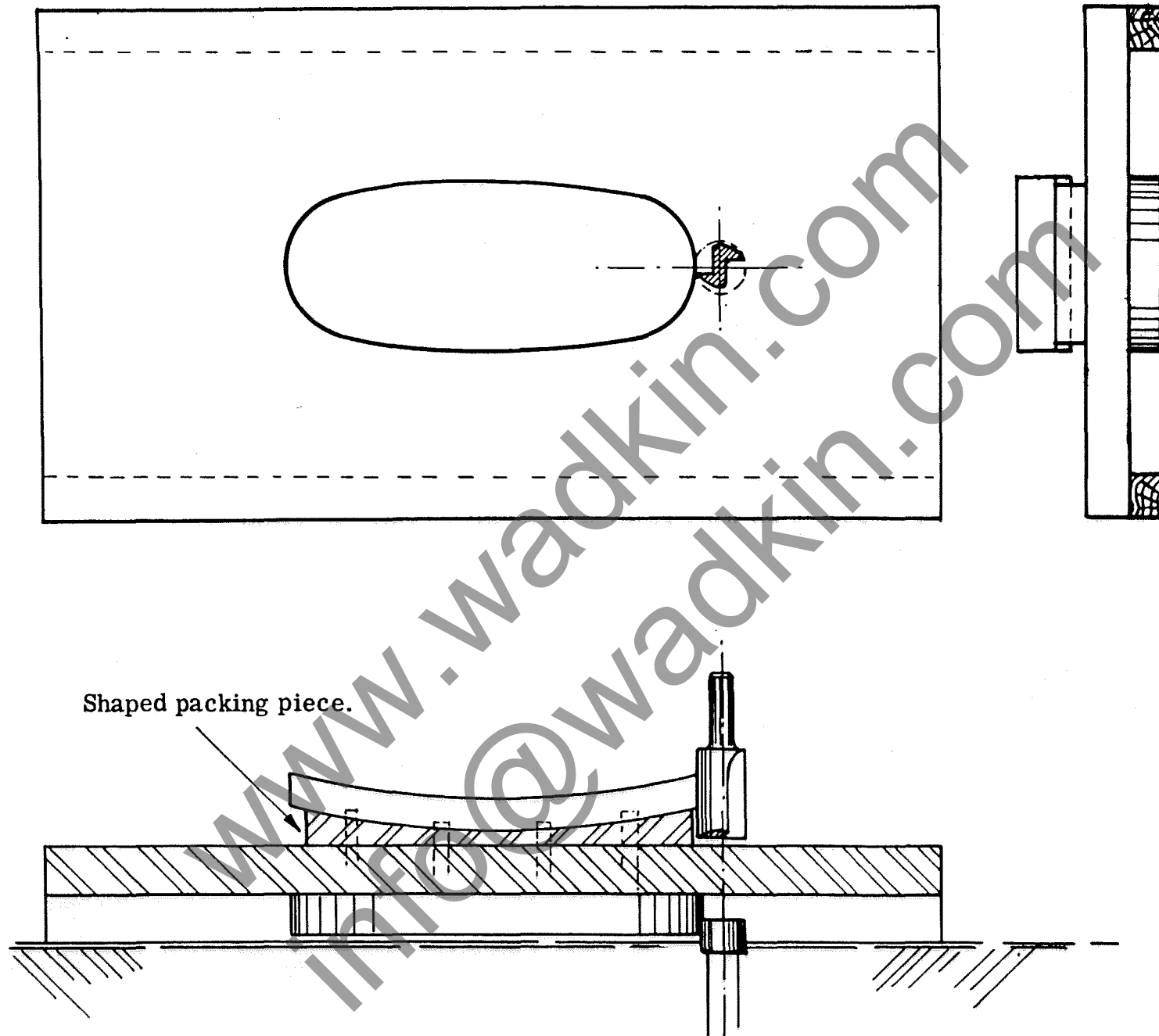

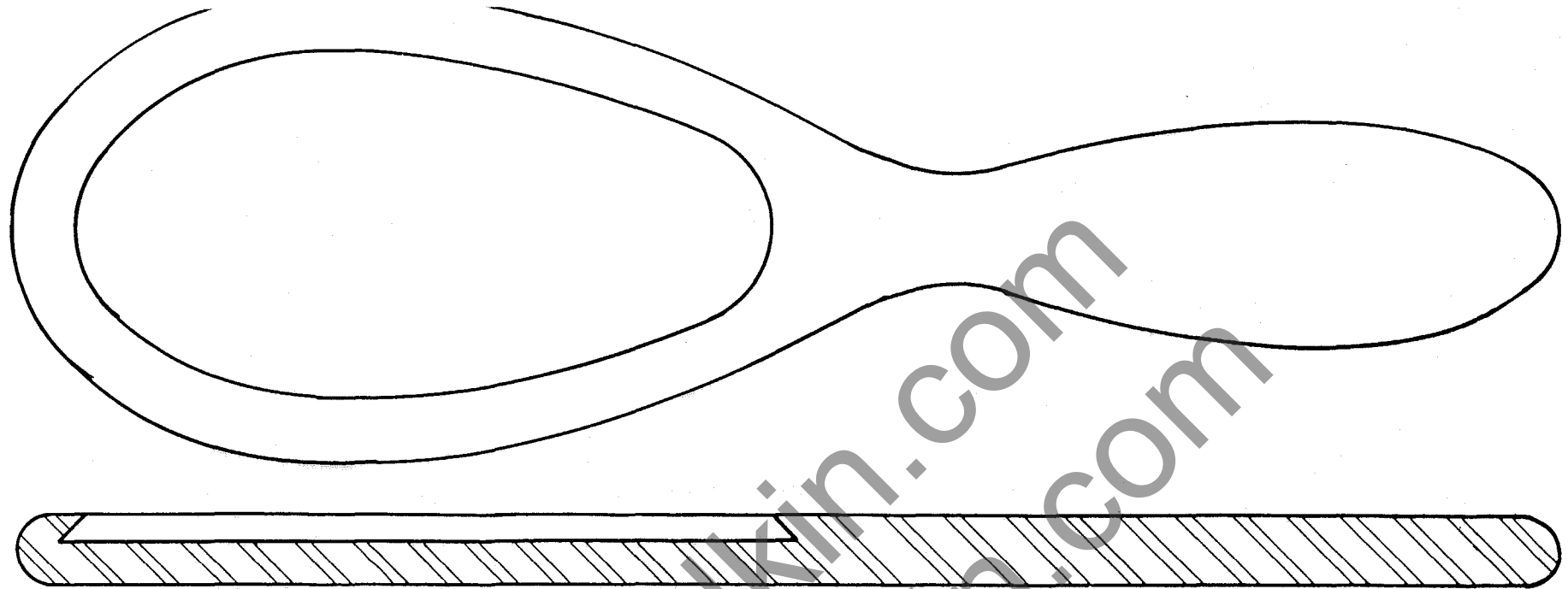

METHOD OF MAKING ROUTER JIGS FOR PRODUCING RECESSED BRUSH BACKS.

Prepare two jig bodies fitted with temporary hardwood rails and under each in turn pin (tack) the master sample brush back.

Mark the face of the jig with both outside profile of brush and shape of recess.

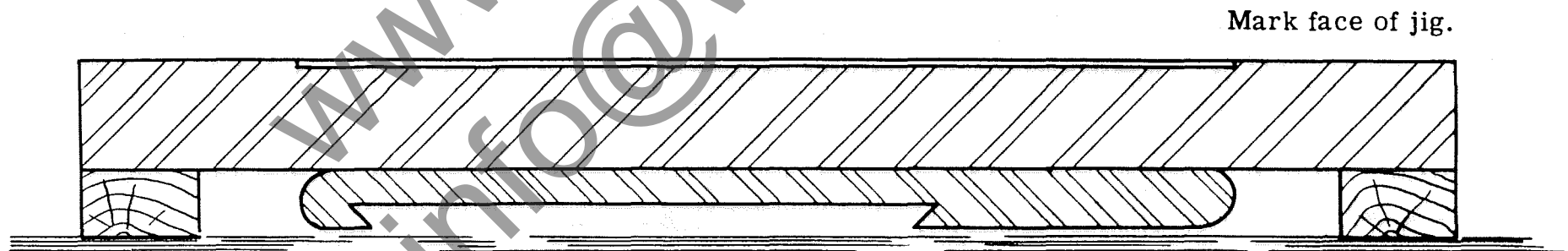

Template material can be mounted on face of jig and cut to shape during this stage of jig making.

FITTING TEMPLATES TO JIG BODIES.

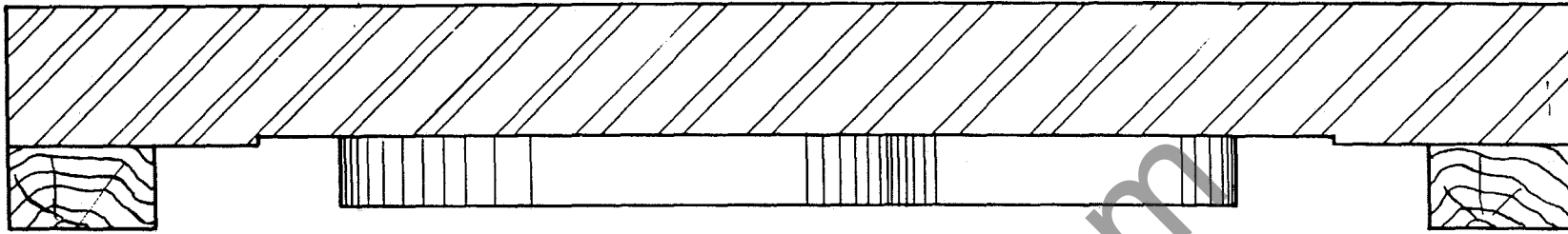

Remove temporary rails from jig body, turn jig over and fit hardwood rails on the opposite side, that is the marked face.

Fit template firmly, locating it from the previously made markings.

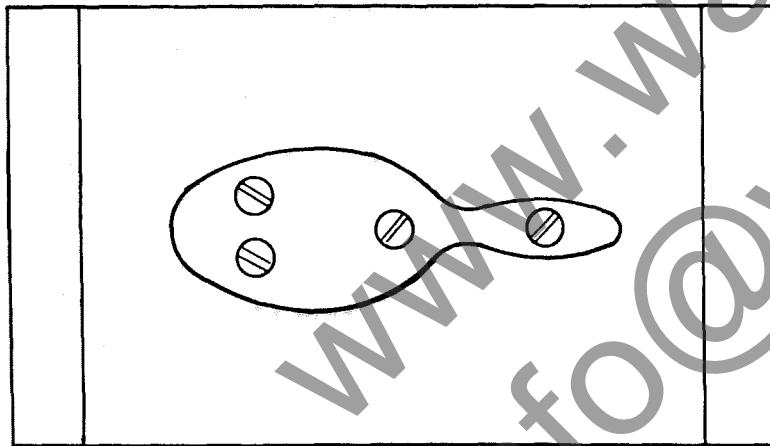

Jig for profiling and shaping 1st operation.

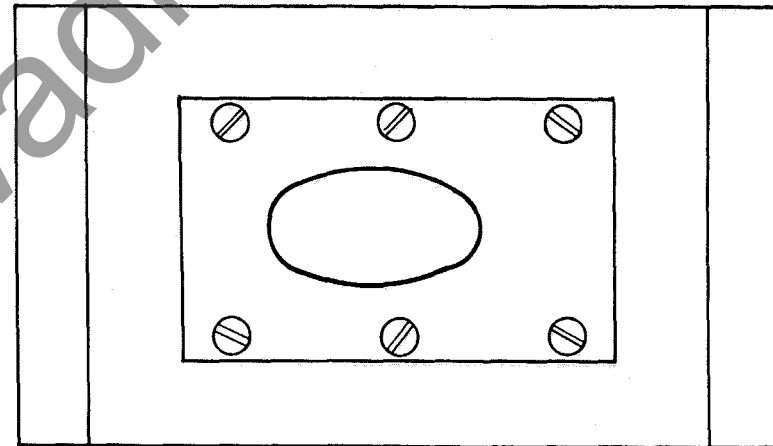

Jig for cutting out recess, 2nd operation.

VIEW OF TEMPLATES FITTED TO JIG BODIES.

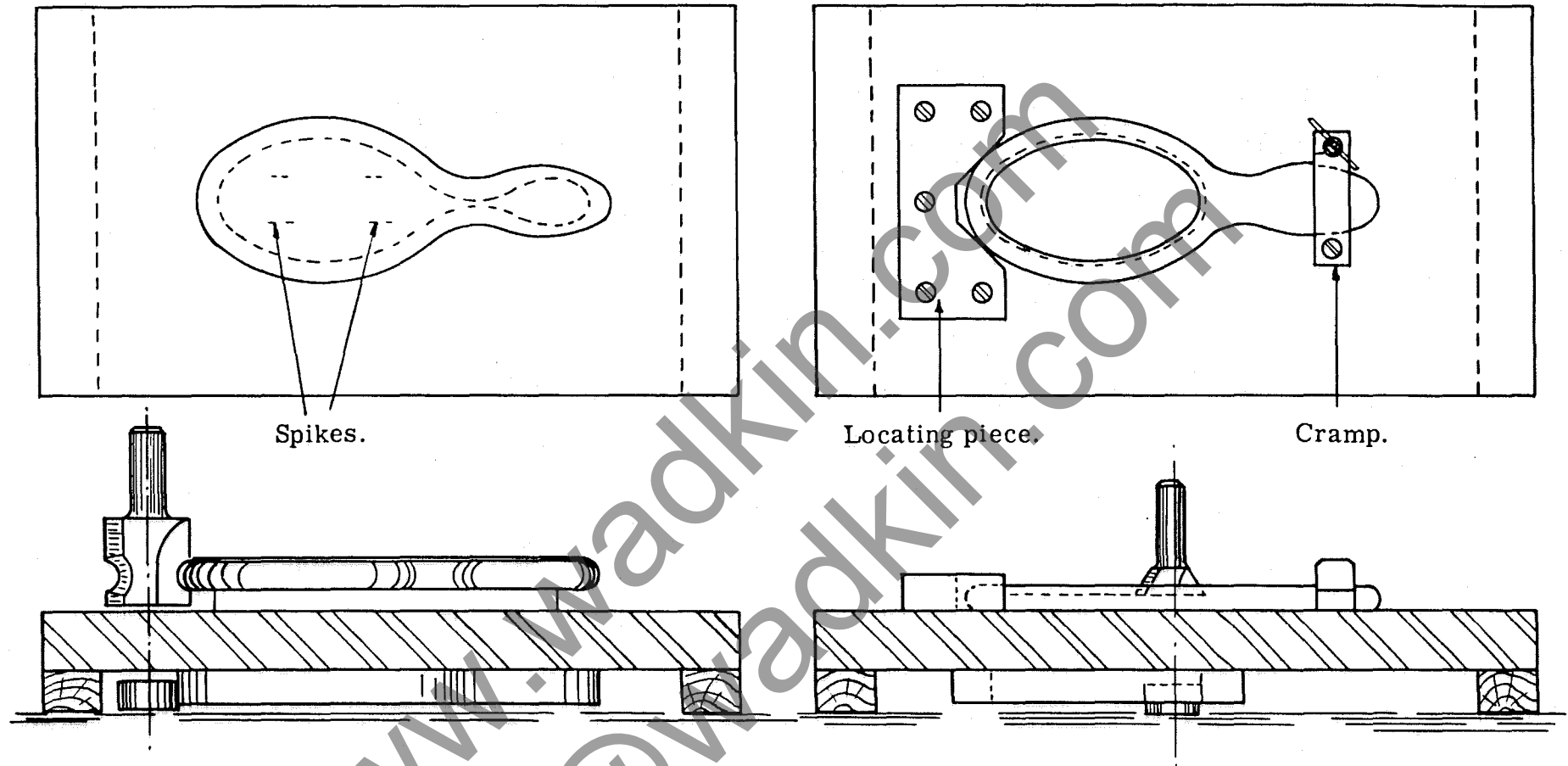

With templates firmly fixed the face of the jigs can be marked to show the position of templates.
 Fix screw for the holding spikes on the profiling jig as described on page 15 and locating piece and
 cramp on the recessing jig.

TYPES OF JIG REQUIRED FOR SHAPING SPECTACLE FRAMES ON ROUTER.

First Operation. Jig for cutting out eye pieces from rough sawn blank.

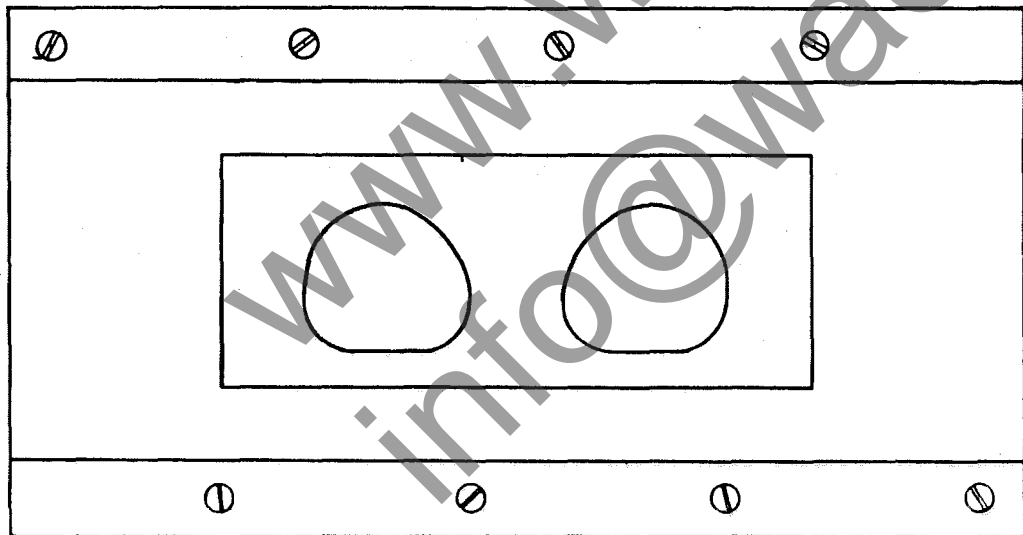
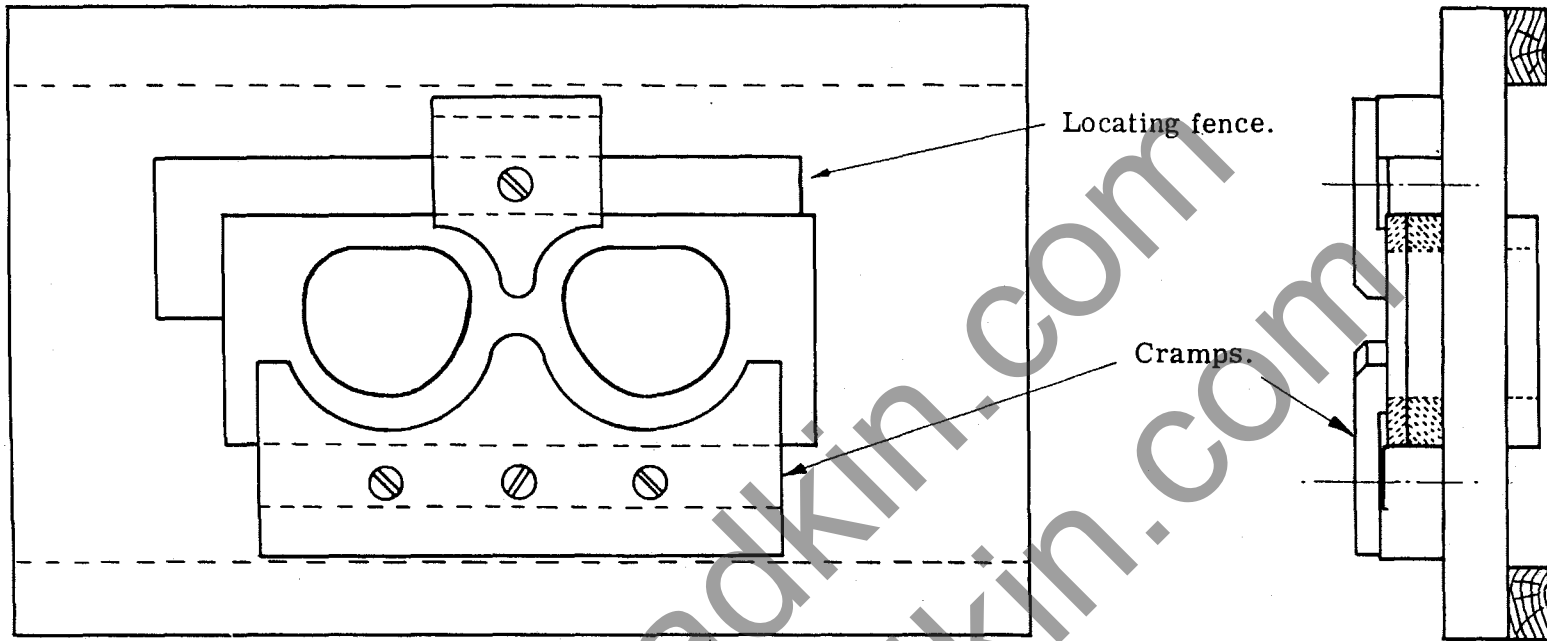

Underside of jig showing template.

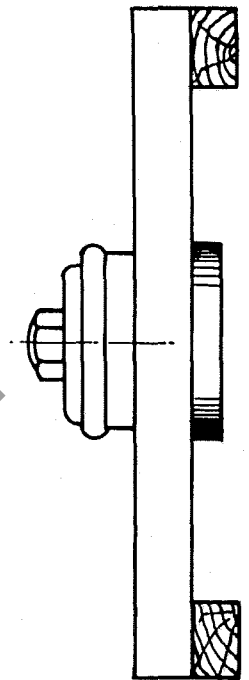
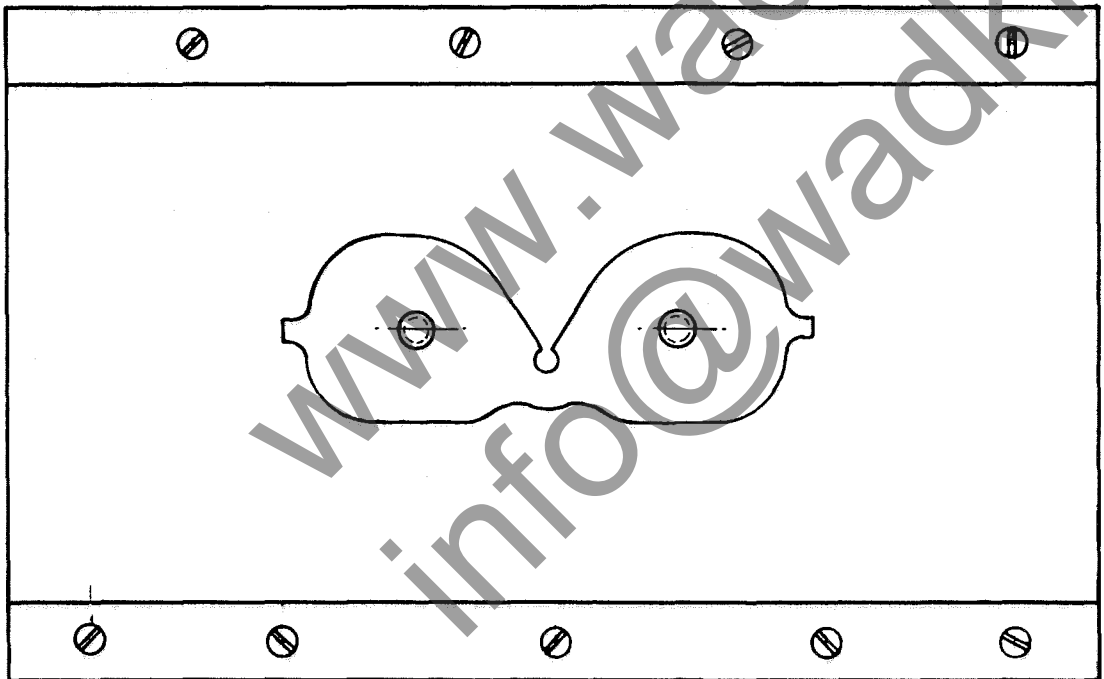
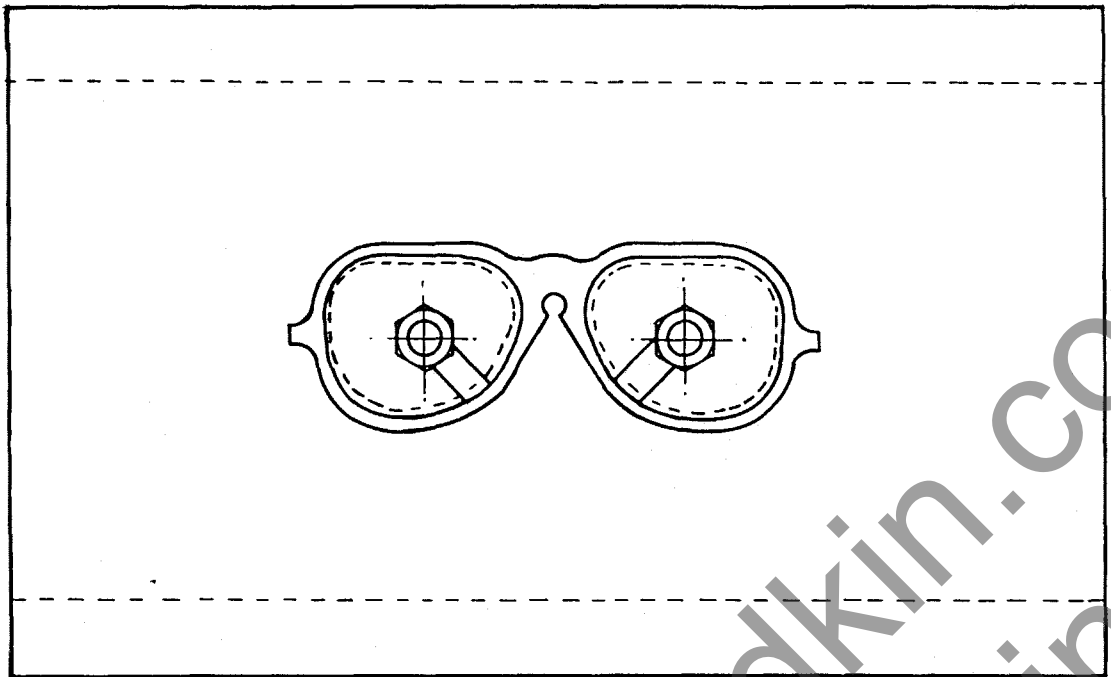

Jig for shaping outsides of spectacle frames.
Locating off previously cut eye-pieces.

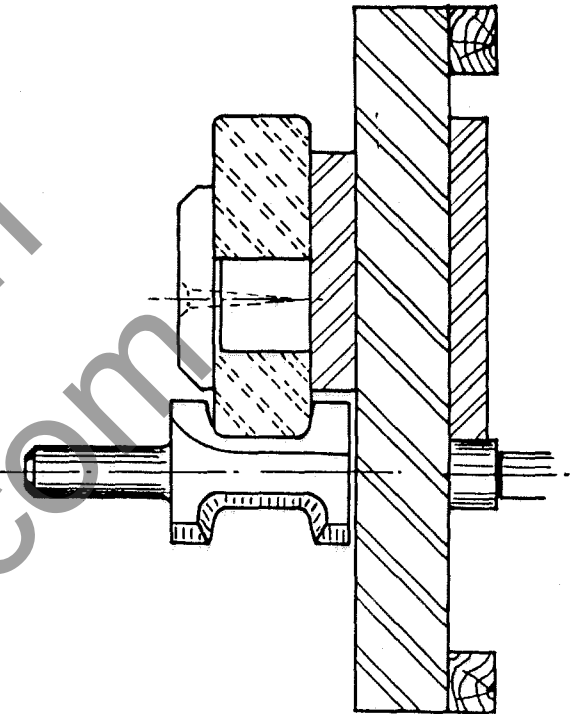
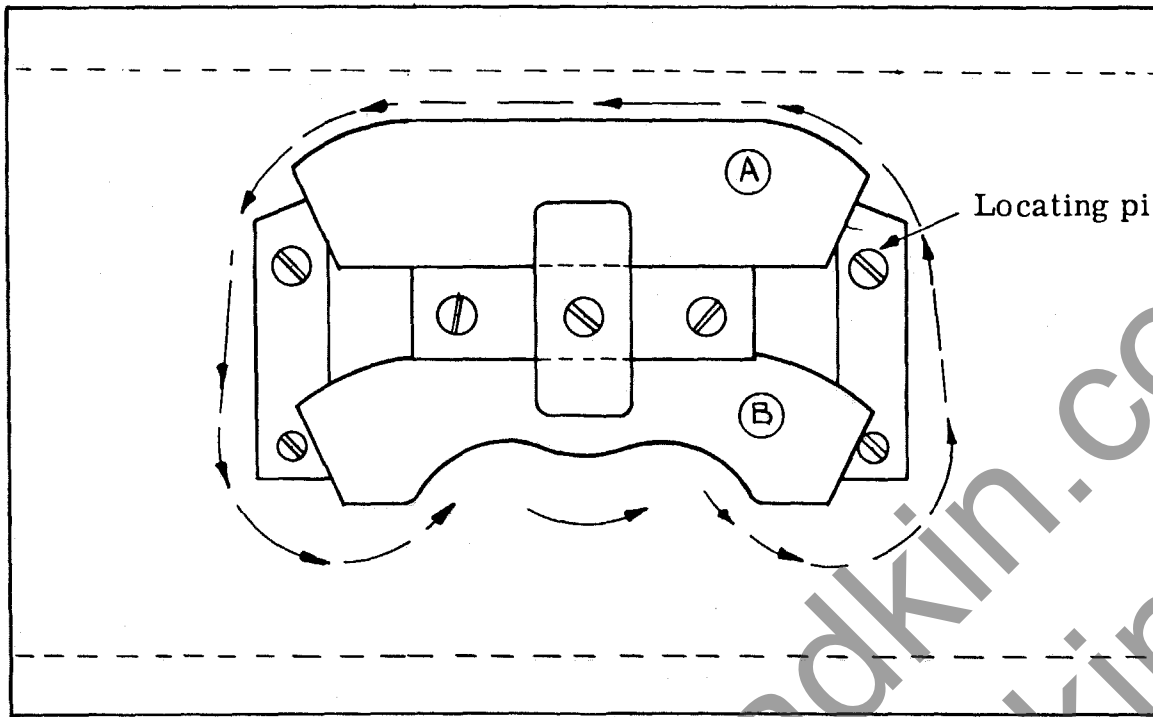

Many articles to be shaped on the router require machining all round, such as bag handles, coat hangers, some types of brush handles, etc. For this class of work it is advantageous to make a jig carrying two components.

METHOD OF OPERATING JIG:-

1. Put prepared blank in position A and rout outer edge.
2. Move shaped blank into position B locating off previously cut edge.
3. Place a new blank in position A. With the jig now fully loaded a finished handle will be produced at each complete circuit of jig.

Actual shape of template.

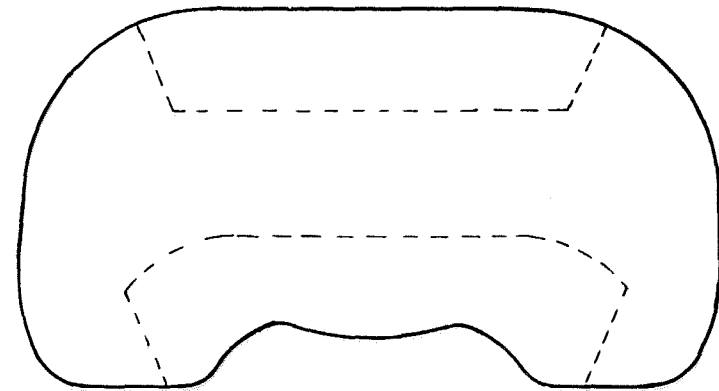

ROUTING OUT HANDHOLES IN CASE
END, SAW HANDLES, ETC.

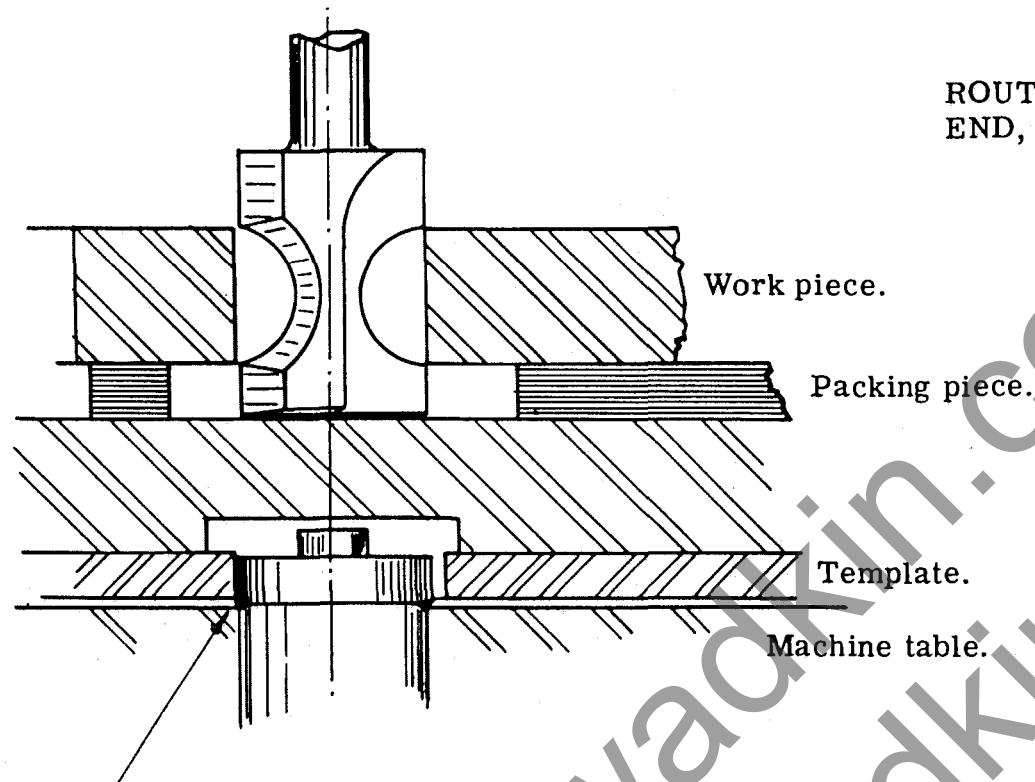

ALWAYS KEEP JIG MOVING WHILST
WORKING CUTTER THROUGH TIMBER.

When sinking cutter through timber the large diameter of former pin engages template, thus cutter is guided through timber without gashing sides of handhole.

When cutter has been worked through timber and reached position required, lower the former pin so that the small diameter engages the template. One pass around the template will then complete the handhole.

To avoid gashing the sides of handhole, when raising the cutter, after finishing the cut, return the large diameter of the former pin into position in the template.

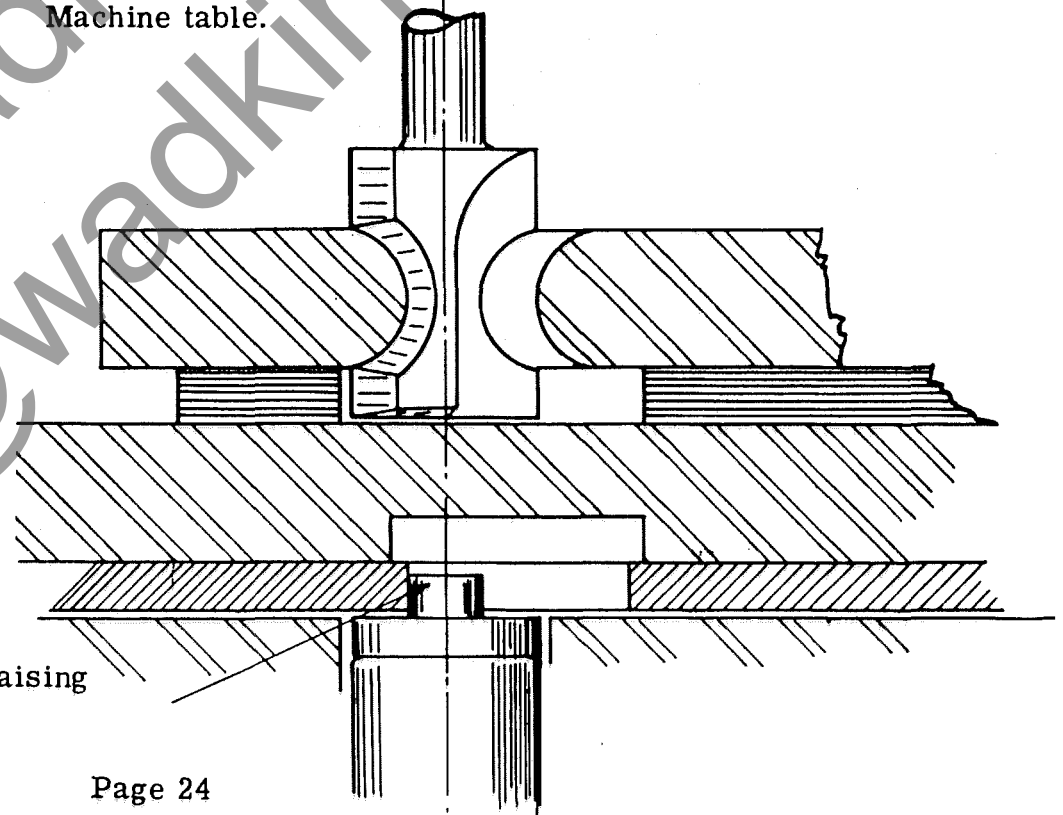

THE DIMENSIONS OF ANY WORK PIECE CAN BE ENLARGED OR DECREASED ON THE SAME JIG BY USING GUIDE PINS OF LARGER OR SMALLER DIAMETER THAN THE CUTTER.

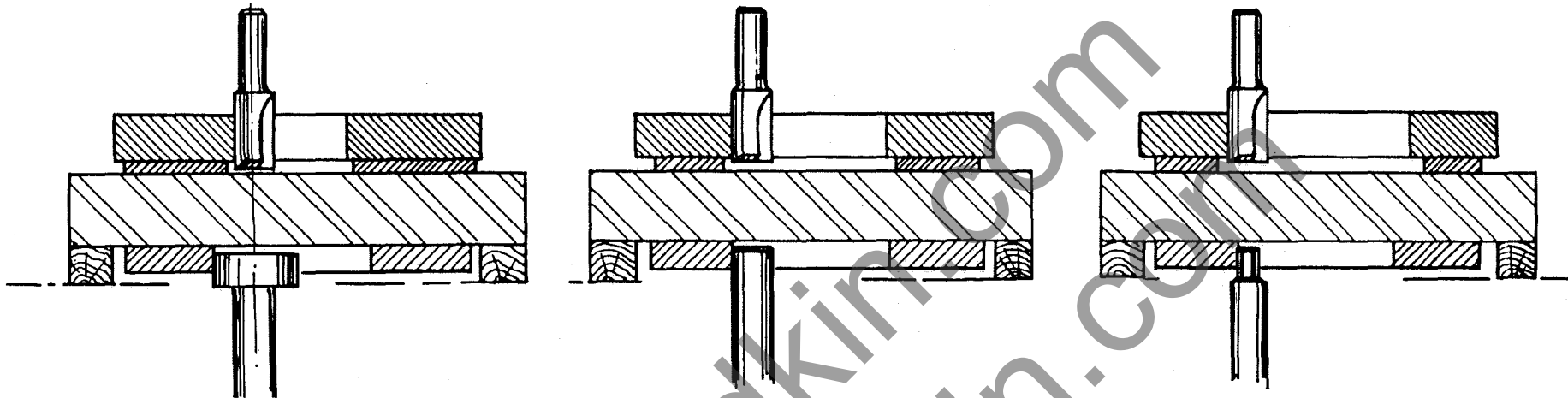

1. Pin larger than Cutter.

2. Pin and Cutter same size.

3. Pin smaller than Cutter.

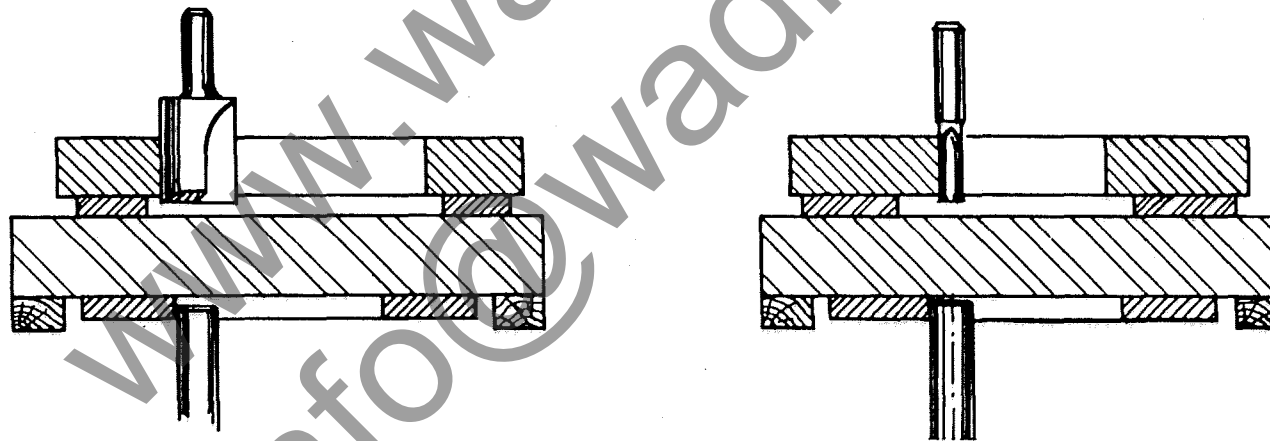

THE SAME RESULT CAN BE OBTAINED BY USING CUTTERS OF VARYING DIAMETER.

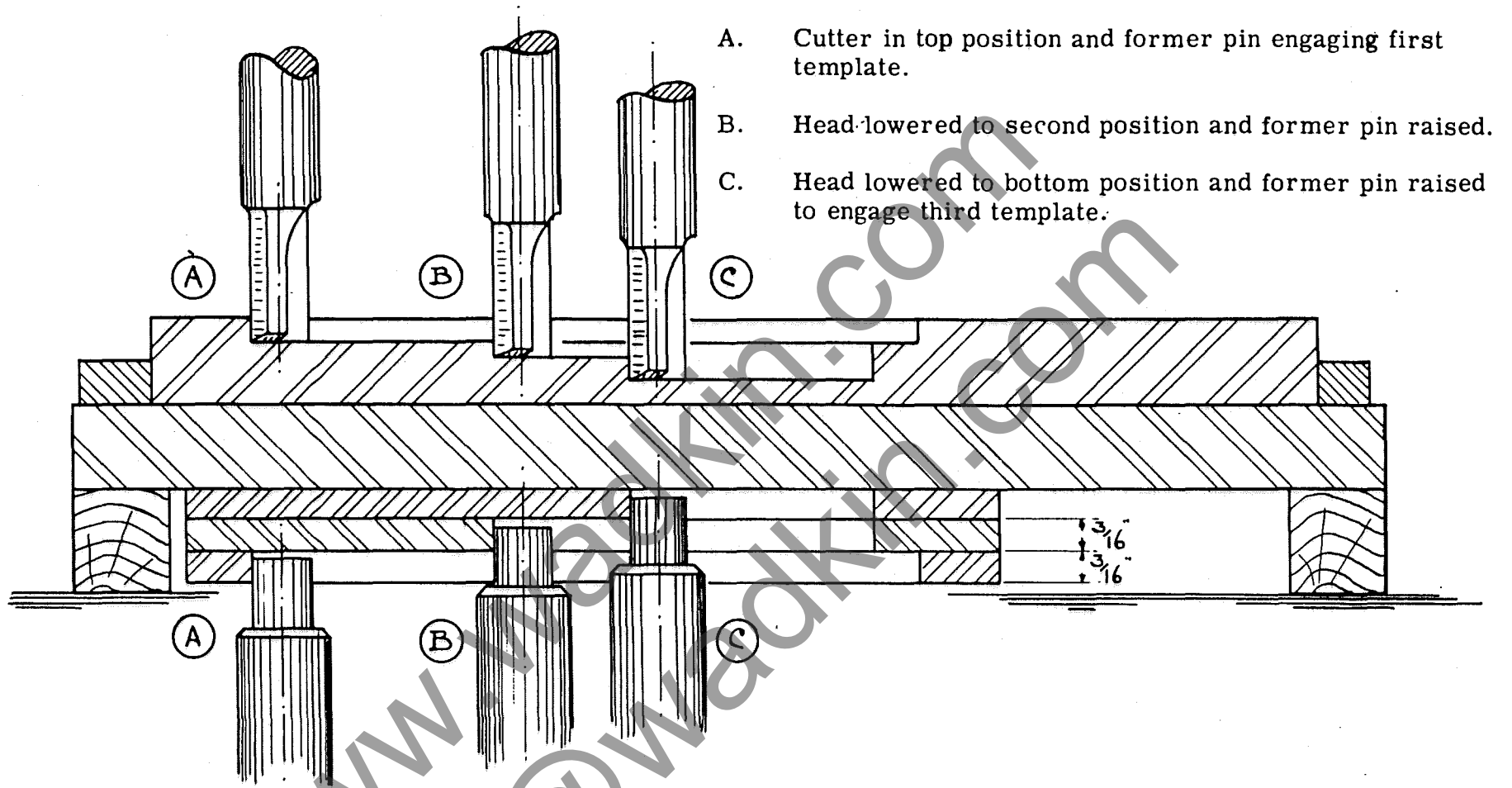

- A. Cutter in top position and former pin engaging first template.
- B. Head lowered to second position and former pin raised.
- C. Head lowered to bottom position and former pin raised to engage third template.

Recesses of various depths such as those in Cutlery trays, Tap and Die cases, types of Brush backs, etc., can be worked by making a jig with multiple templates. Each template corresponding to the recesses of one depth. Mount the templates in one pack on the jig body and raising the former pin by the hand lever on the front of the machine table - each template can be engaged in succession. The various depths of cut are pre-set by the variable stops on the router head.



Finished article.

Section across tray.

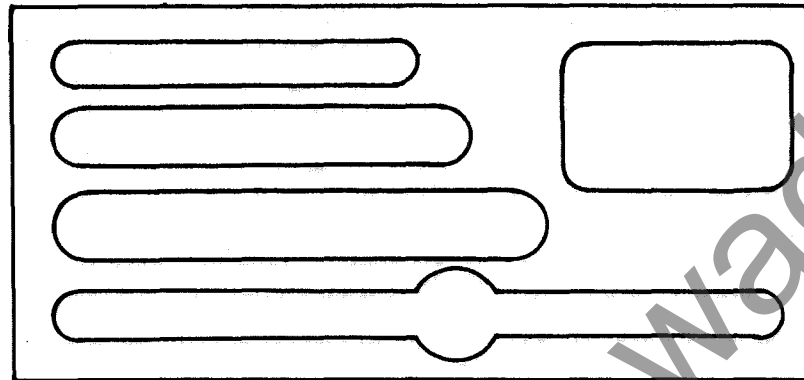
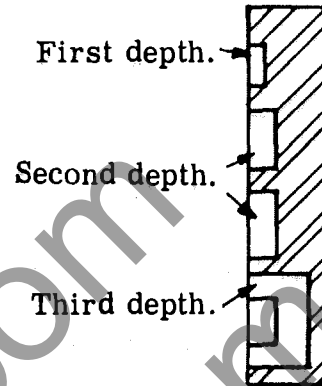

First template "A"

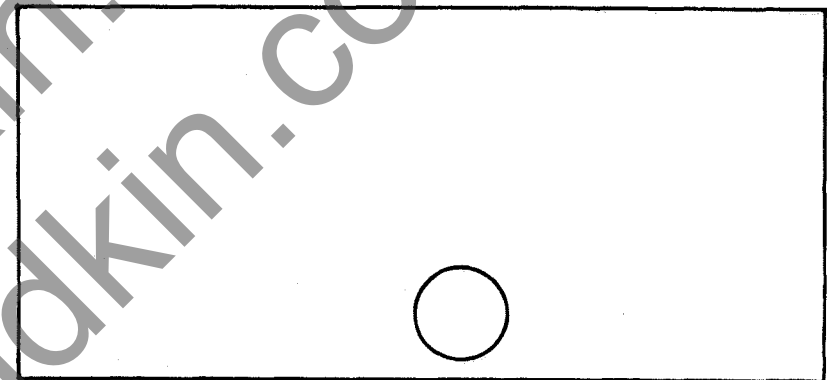

Third template "C"

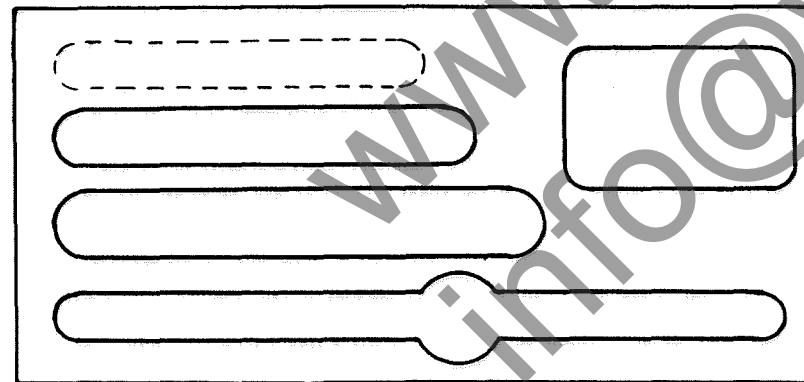

Second template "B"

Details of templates for working recesses of various depths.

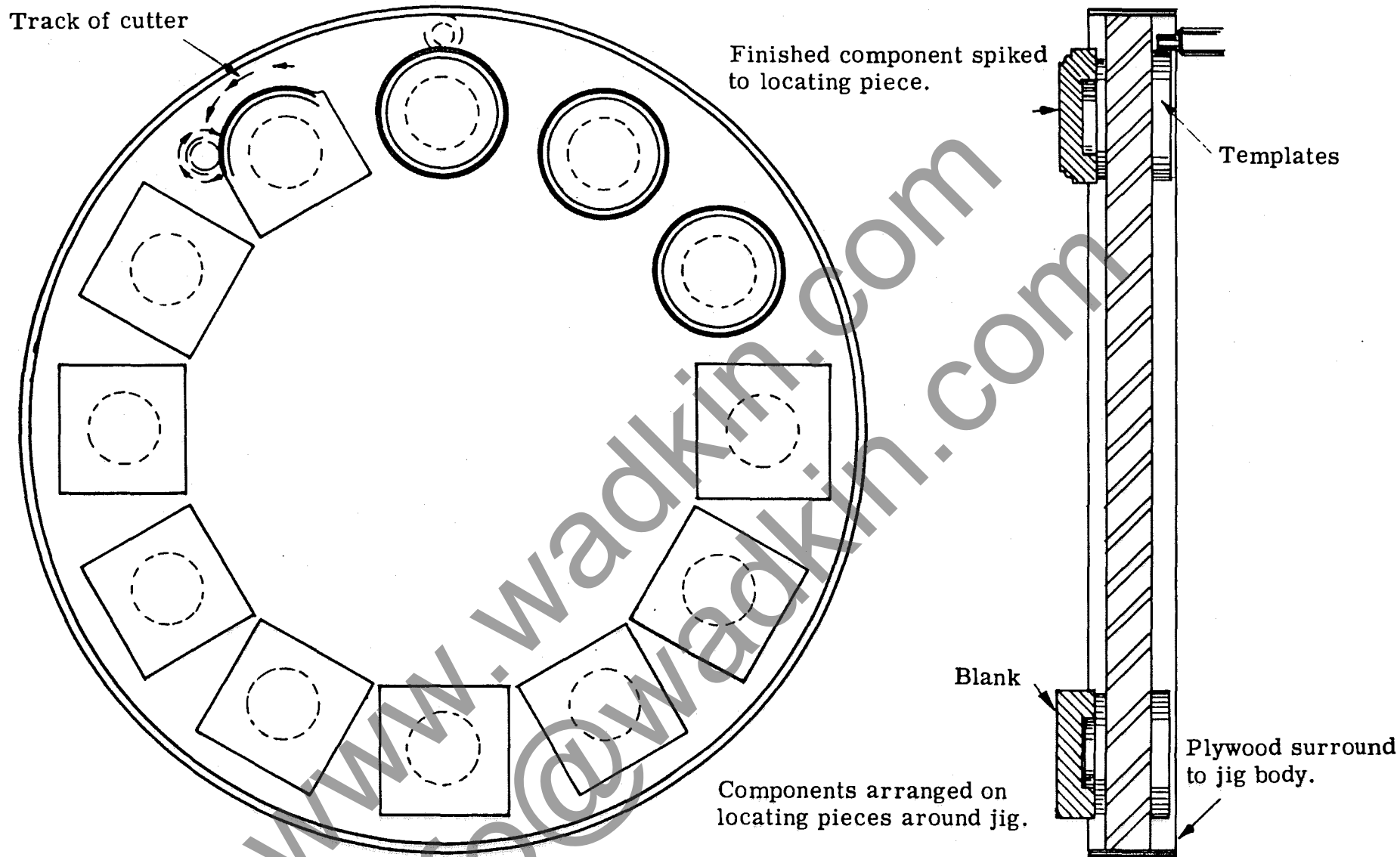

When large quantities of any small articles such as electric light ceiling rosettes, etc., are to be made, it is often advantageous to build a circular jig carrying a number of components. By using this type of jig the operator's position in relation to the machine is constant and excessive movements of the hands avoided.

To maintain constant production, duplicate jigs can be used, one being reloaded whilst operator routs with second jig. This eliminates idle machine time.

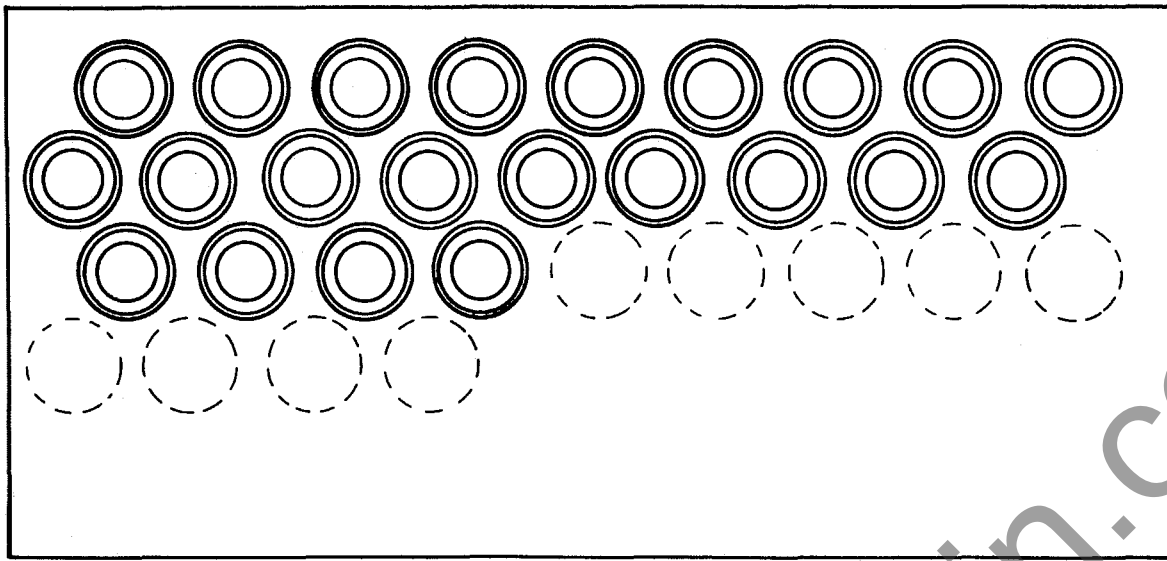

Routed face of wood.

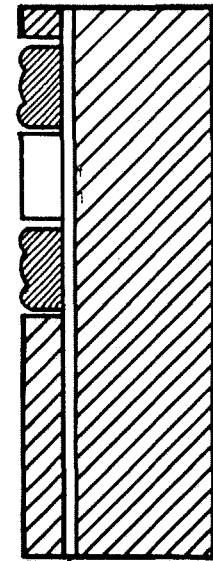

Saw-cut.

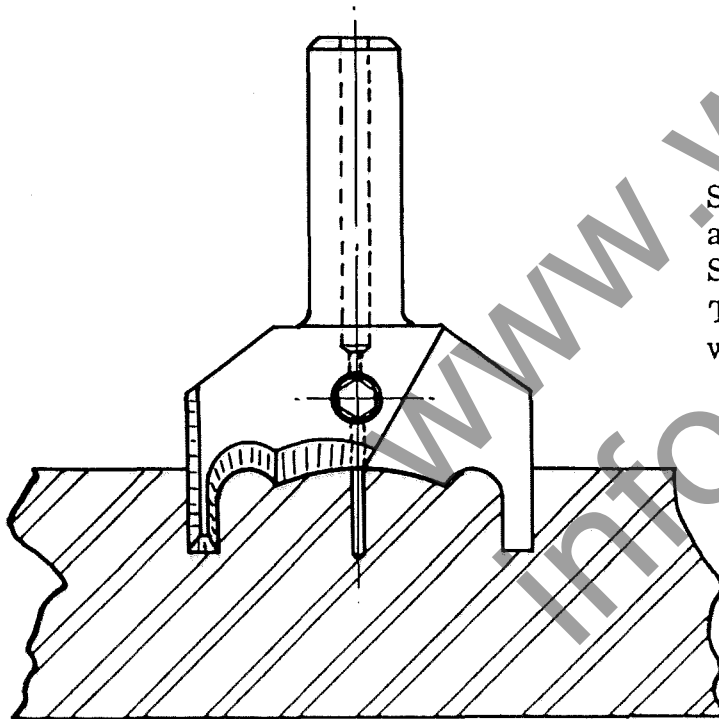

Small circular objects and wheels for toys can be made by sinking a special shaped cutter into the surface of any suitable wood. Saw off the routed face then the wheels will fall loose. The routing operation can then be repeated on the stock piece of wood if of suitable thickness.

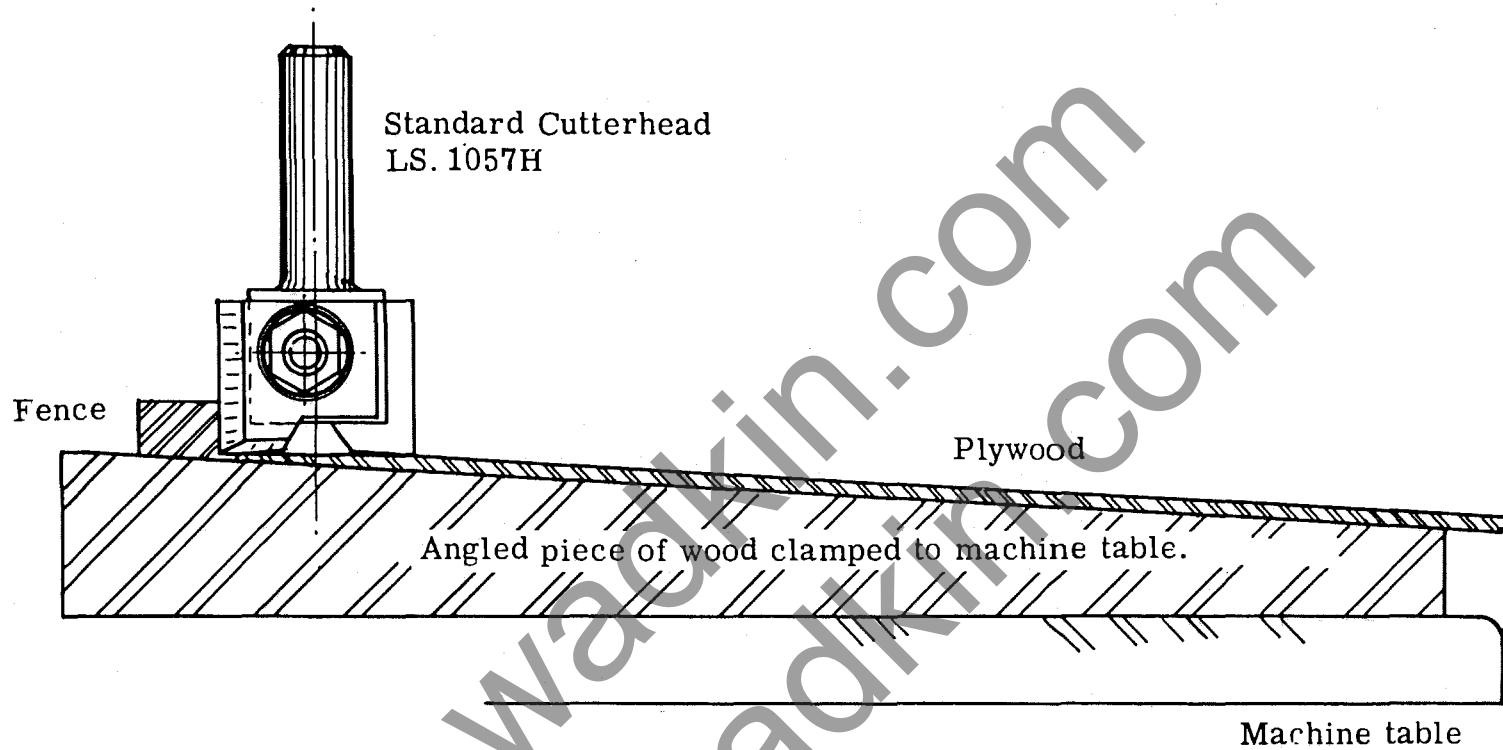

METHOD OF SCARFING PLYWOOD, ETC. , ON A WADKIN ROUTER.

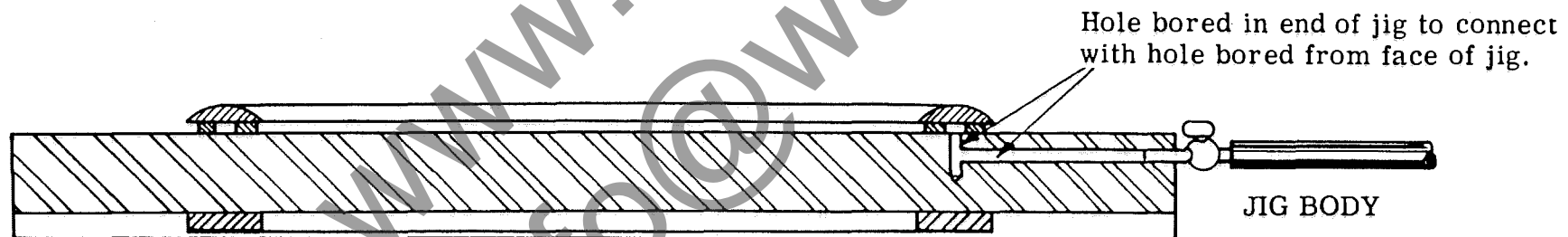
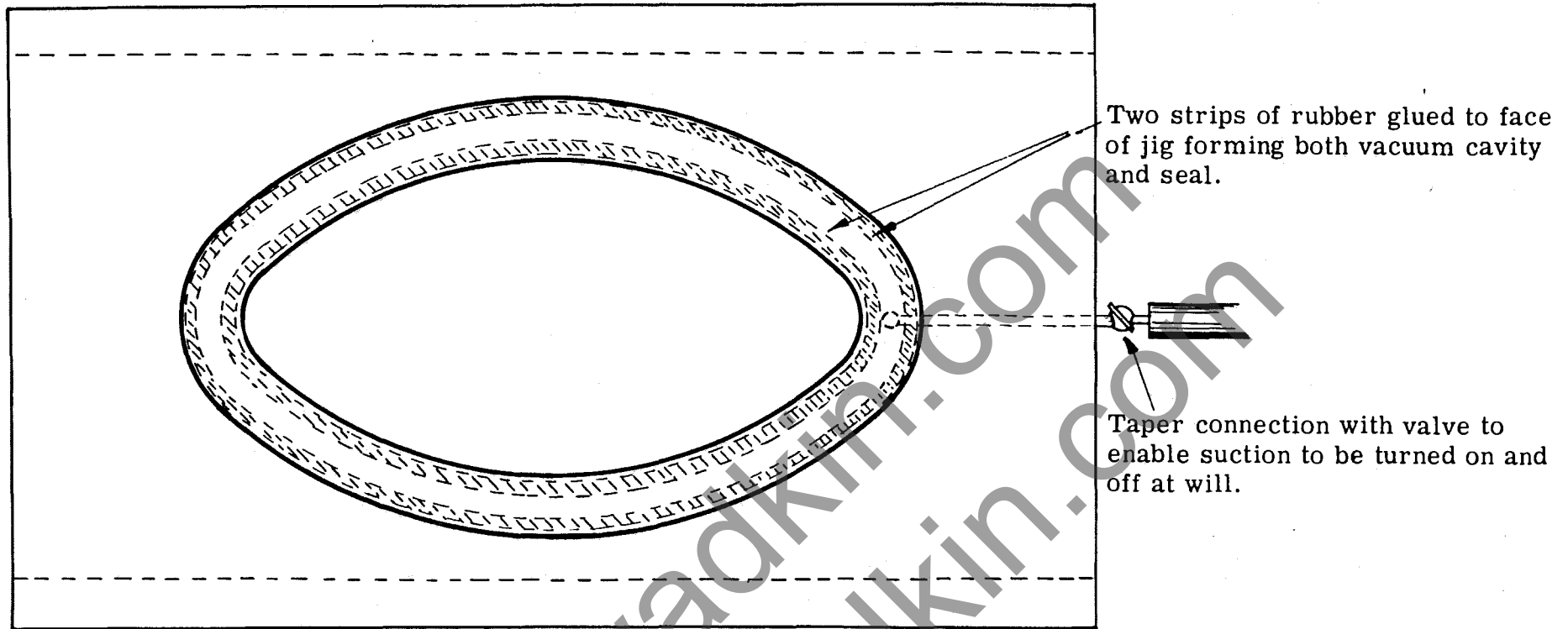

Plastic components, draughtsmen's protractors, or any light article requiring routing all round can be produced by making a jig whereby the components are held by suction. Two rubber strips are glued to face of jig conforming to the profile of the component. Place the blank component on the rubber and exhaust the air from between the strips. Blank will now be held firmly during routing.



Type of jig required for
shaping and moulding curved
chair backs, etc.

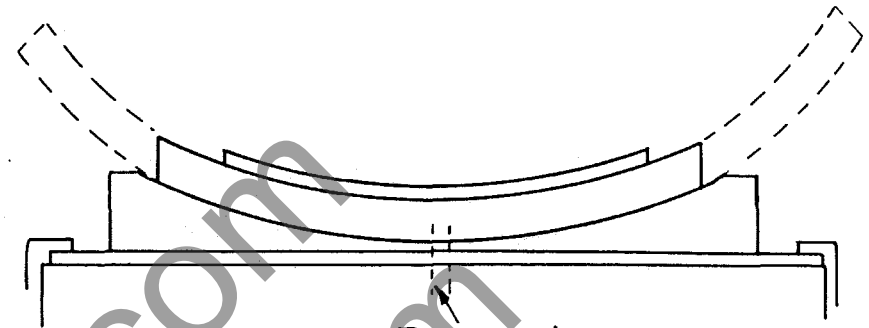

Former pin

Shaped table cramped
to router table.

Cradle to carry
curved chair back.

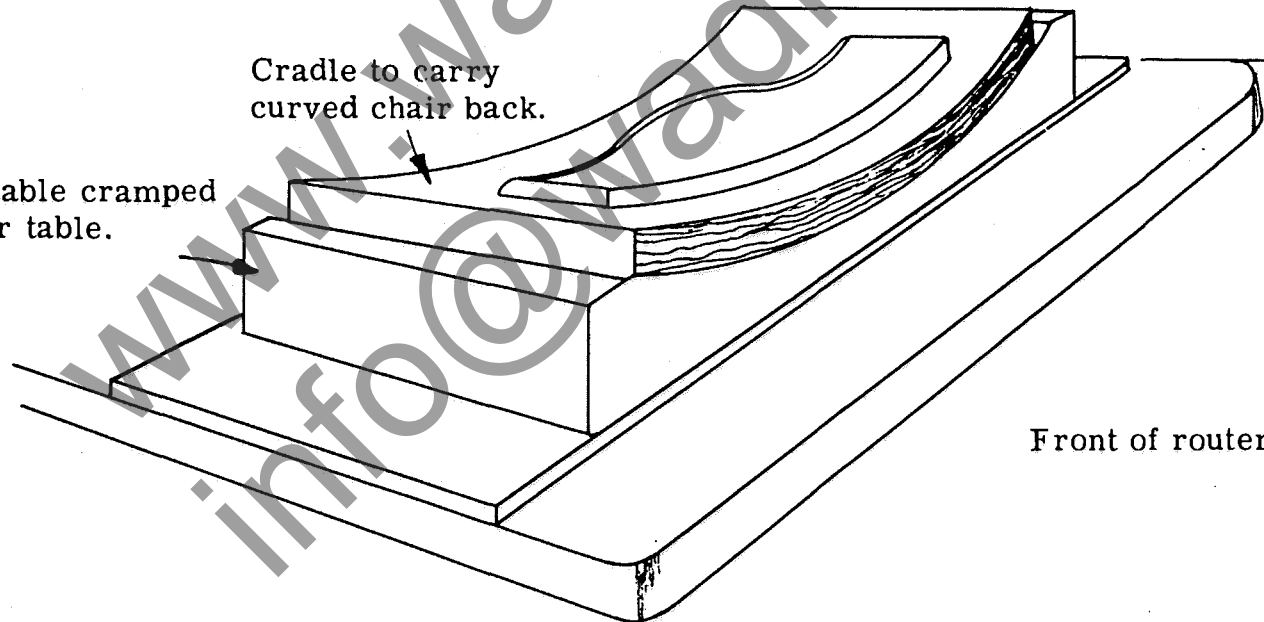

Front of router table.

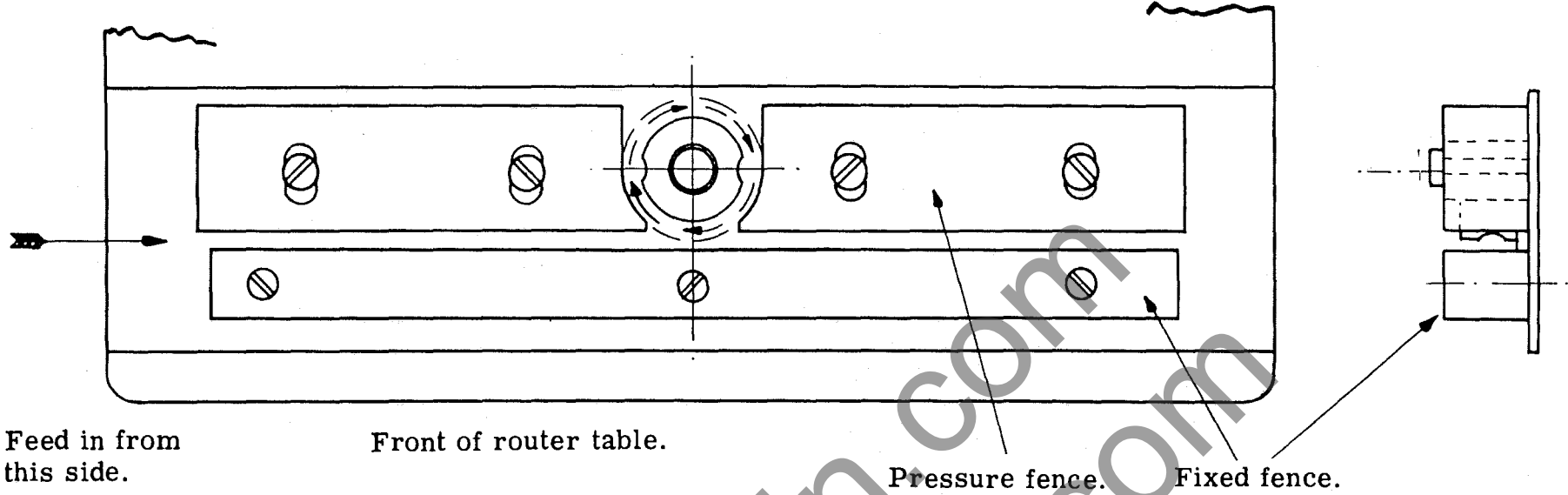

Simple type of pressure fence to enable small mouldings, beads, etc., and thicknessing to be worked on Router.

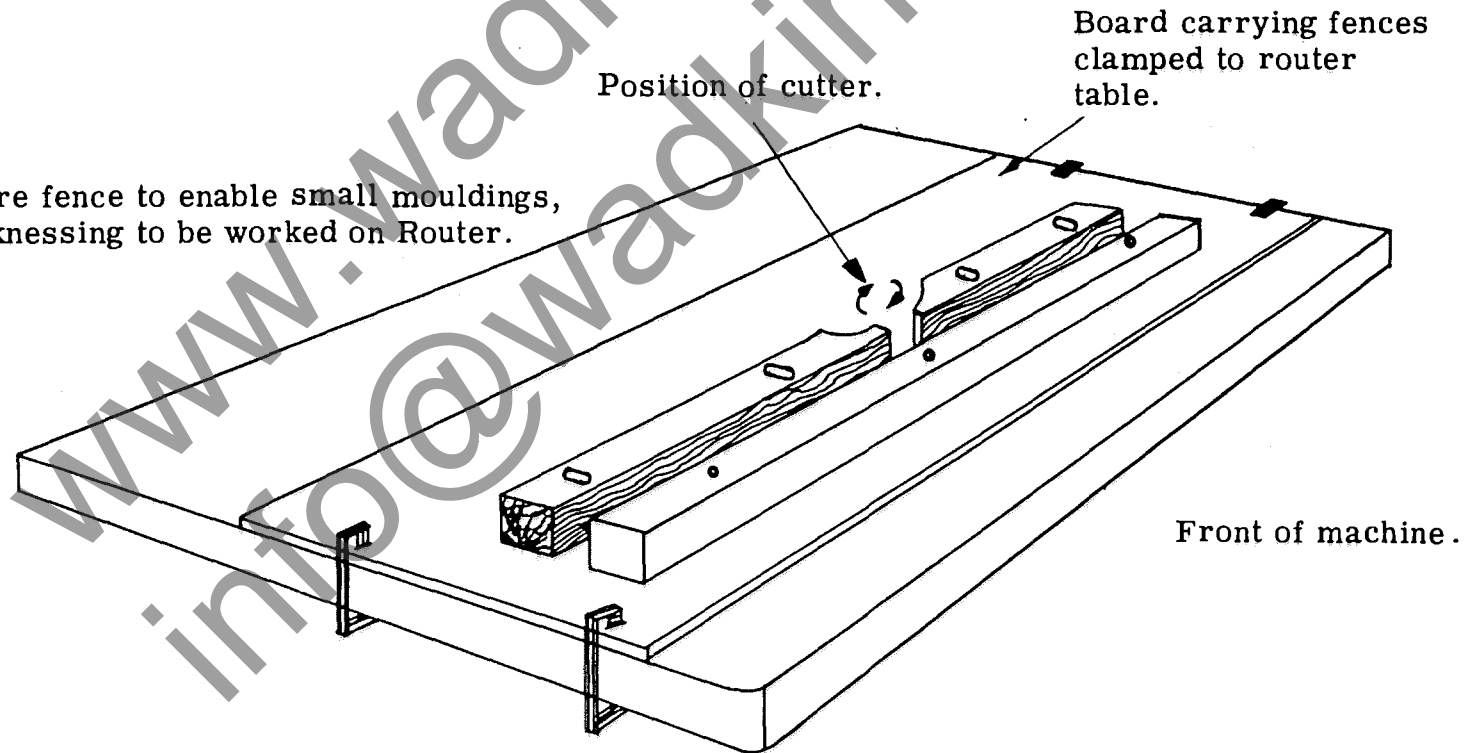

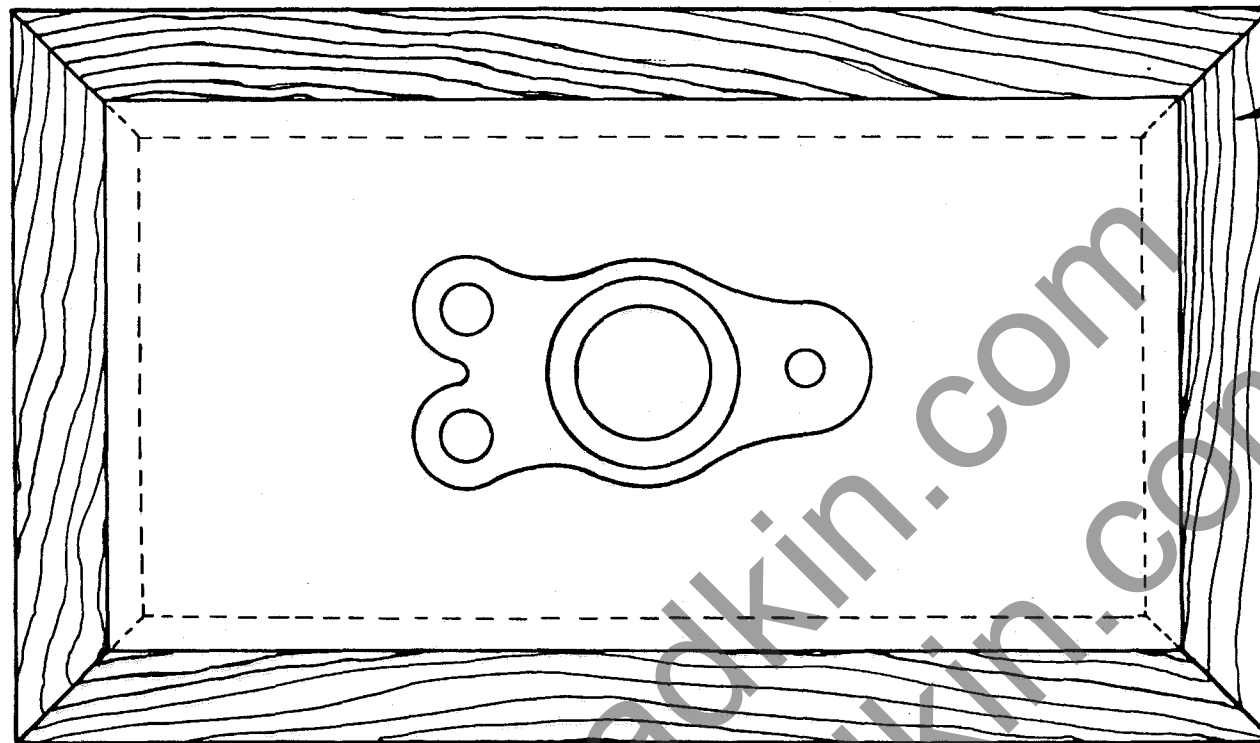

Hardwood frame
around composition
or aluminium jig body.

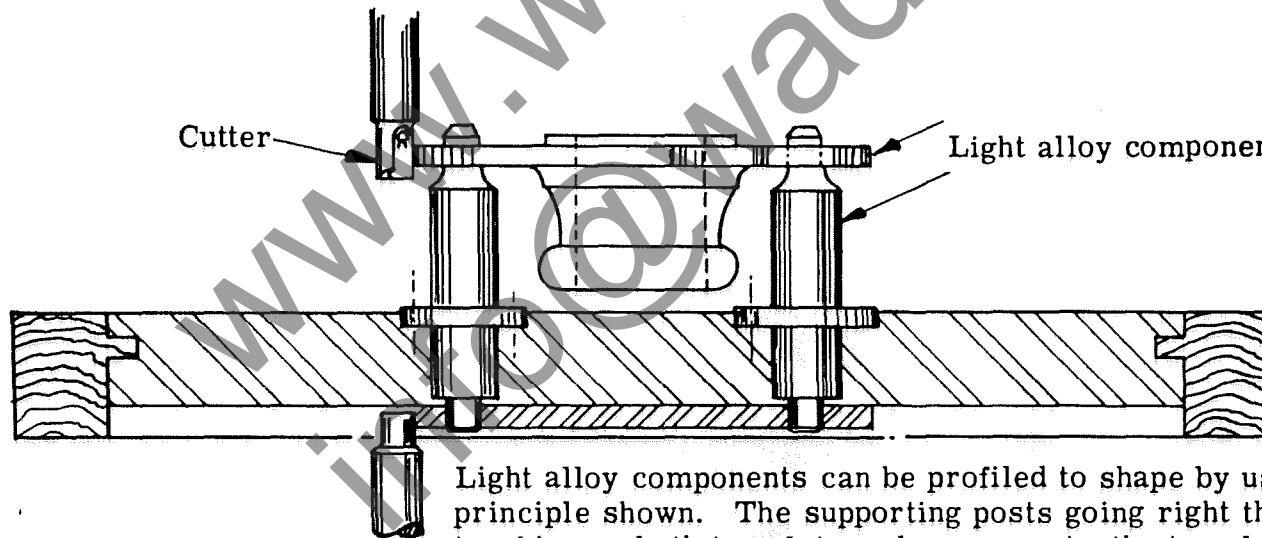

Cutter

Light alloy component supporting posts.

Light alloy components can be profiled to shape by using a jig made on principle shown. The supporting posts going right through jig body, tracking up both template and component, the template having exactly the same profile and tooling holes as component.

ECCENTRIC CHUCKS

For slotting, small mortices, grooving, etc., where constant cutting diameter is important, the use of an eccentric chuck is advised.

The cutters are only sharpened inside the flute. Providing the cutting edge is always set in position, between the 30° and 50° marks as shown in diagram, the effective cutting diameter will never decrease.

It is important that the right combinations of cutter and chuck as set out on the chart are maintained. If not, cutter burning and poor work will result. Eccentric chucks must be balanced carefully.

SIZE OF CHUCK	DIAMETER OF CUTTER				EFFECTIVE CUTTING DIAMETERS			
1/32	1/8	5/32	3/16		5/32	3/16	7/32	
3/64	1/8	5/32	3/16	7/32	11/64	13/64	15/64	17/64
1/16	3/16	7/32	1/4	5/16	1/4	9/32	5/16	3/8
3/32	1/4		5/16	3/8	11/32	13/32		15/32
1/8	5/16	3/8	13/32	7/16	7/16	1/2	17/32	9/16
5/32	3/8	13/32	7/16	15/16	17/32	9/16	19/32	5/8

DIMENSIONS OF CUTTERS FOR ECCENTRIC CHUCKS.

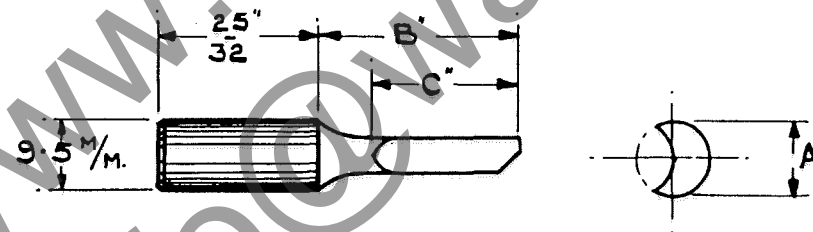

A	1/8"	5/32"	3/16"	7/32"	1/4"	5/16"	3/8"	13/32"	7/16"	15/32"	1/2"
B	31/32"	31/32"	31/32"	31/32"	1. 3/16"	1 3/8"	1 3/4"	1 3/4"	1 3/4"	1 3/4"	1 3/4"
C	9/16"	9/16"	5/8"	5/8"	3/4"	7/8"	1 1/8"	1 1/8"	1. 3/16"	1. 3/16"	1 1/4"

Eccentric chuck.

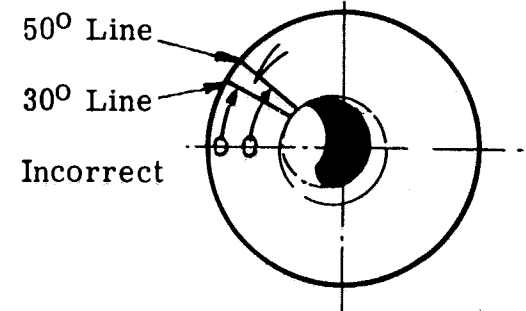
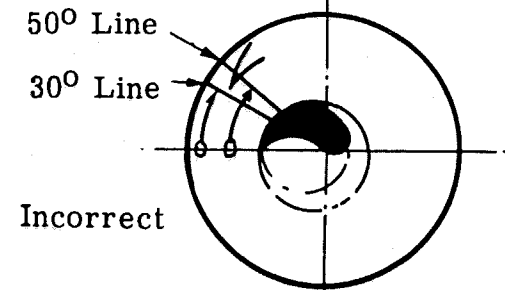
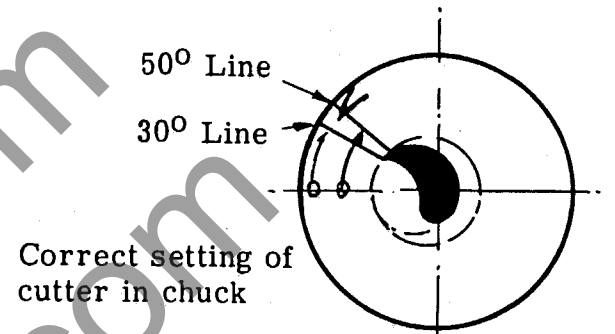
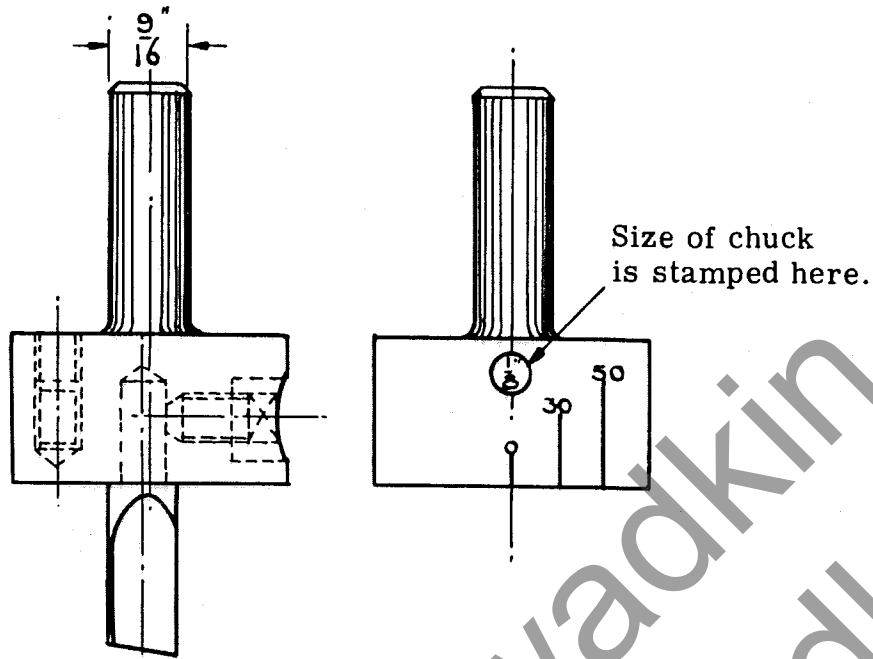

To find the cutting diameter of any respective chuck and cutter, add the chuck size to the diameter of the cutter. The cutting edge of the cutter must be either on or between the lines marked 30°-50° to ensure cutter clearance and the best cutting angles.

With cutter so set a chuck marked $\frac{1}{16}$ " and a cutter $\frac{1}{4}$ " diameter will cut $\frac{5}{16}$ " diameter.

It is important that an eccentric chuck should be balanced every time the cutter is changed. The cutter being set in its correct cutting position before the balance operation is carried out.

Balancing plate is levelled by means of three adjustable screws. Then the chuck is inserted in the balancing roller and the correct balance is obtained by inserting or withdrawing balancing screws. When the chuck is perfectly in balance the roller will come to rest in any position.

The plate can be levelled by testing with the balancing roller only, or spirit level. Great care must be taken with the roller, never allowing the rims to be bruised.

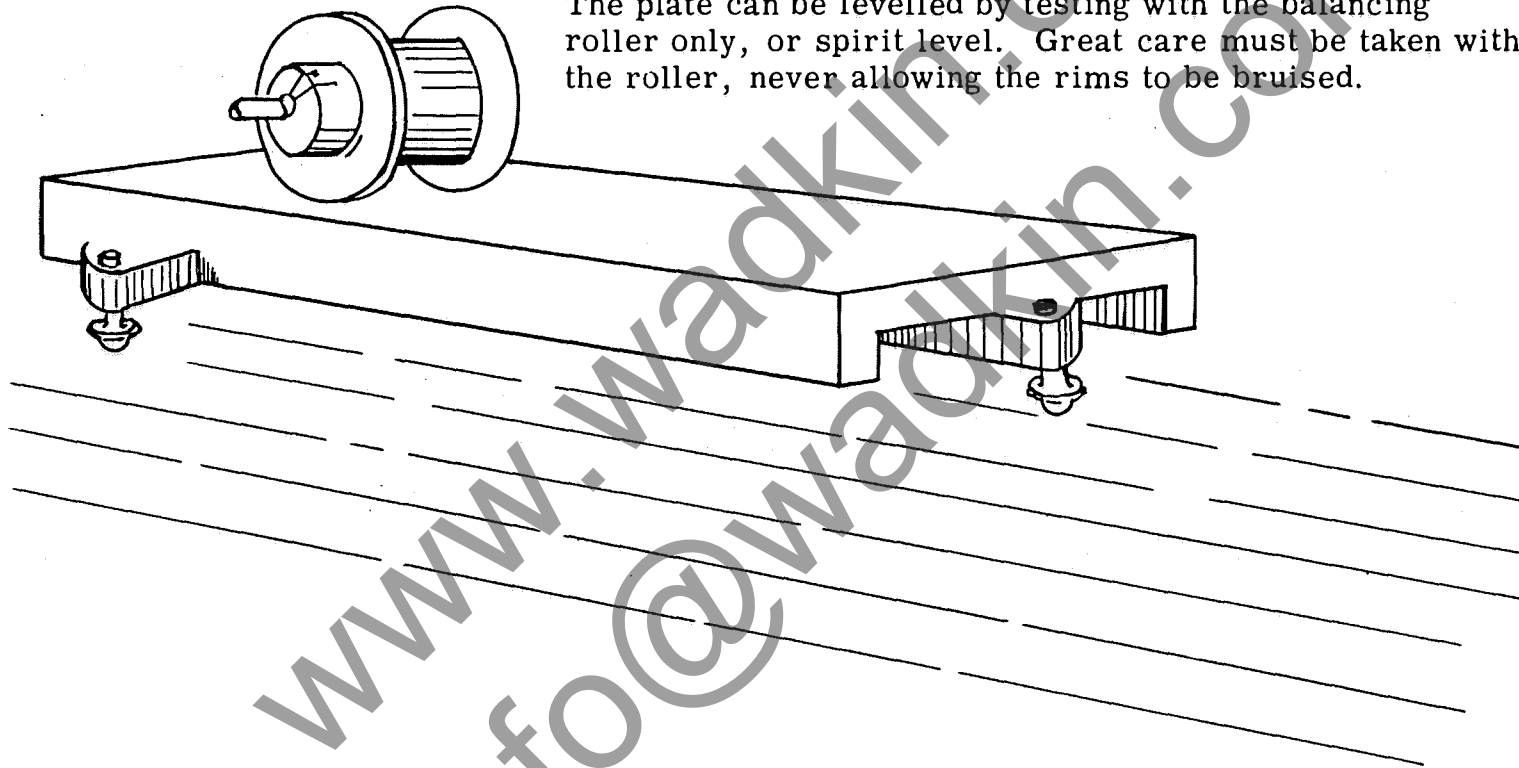

EXAMPLES OF EXTREME CUTS POSSIBLE ON WADKIN ROUTER.

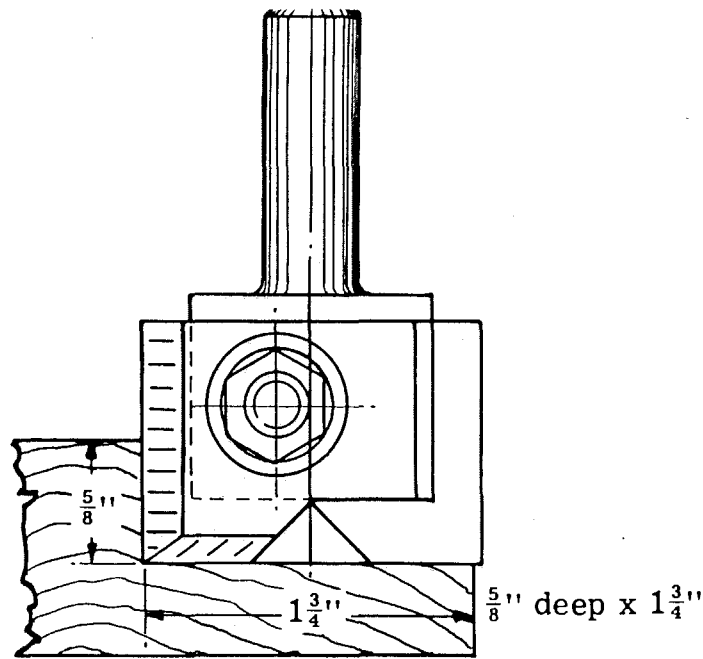

Rebating across or with the grain.

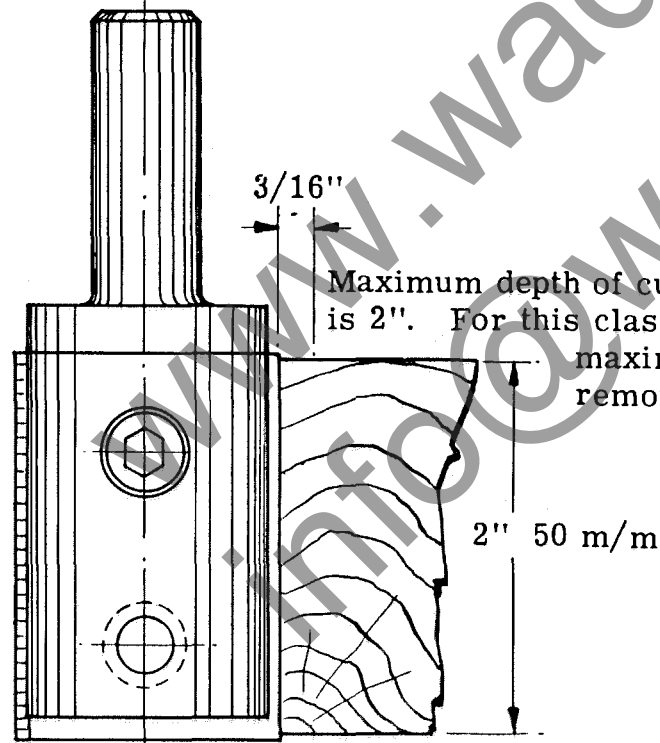
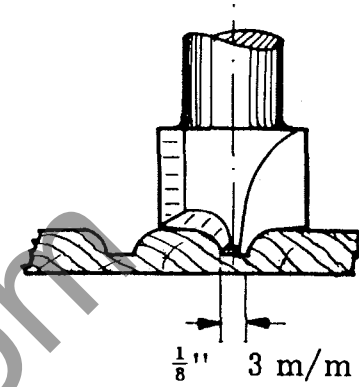
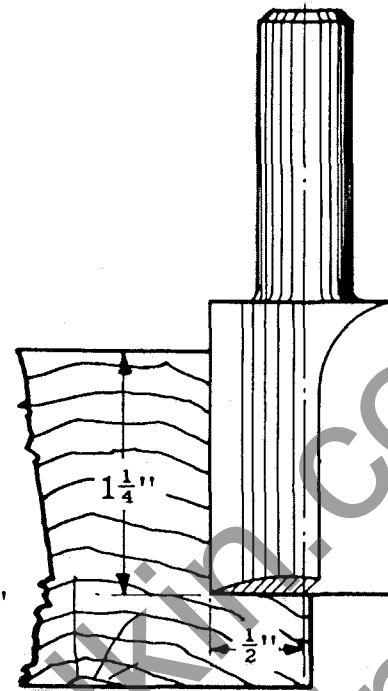

Maximum depth of cut when edging shaped work is 2". For this class of routing 3/16" is the maximum amount of wood to remove continuously.

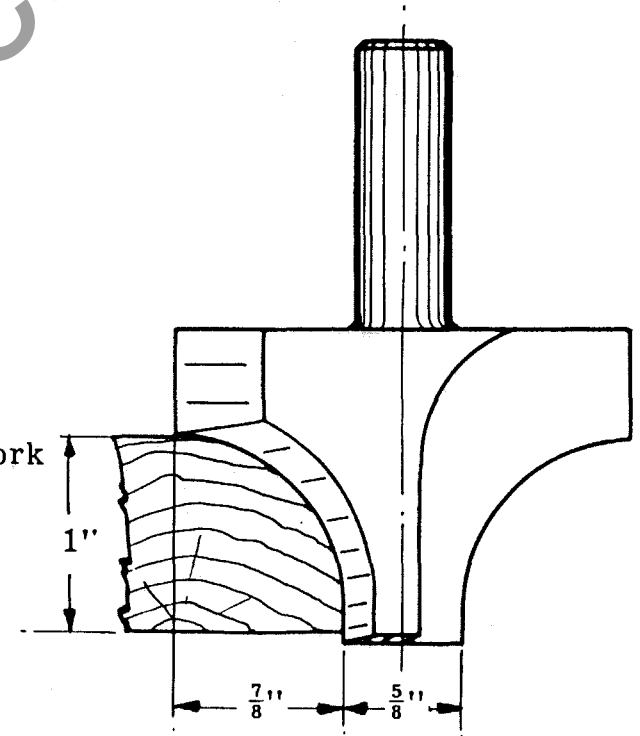

Maximum dimension of moulding on Router.

EXAMPLES OF EXTREME CUTS POSSIBLE ON WADKIN ROUTERS.

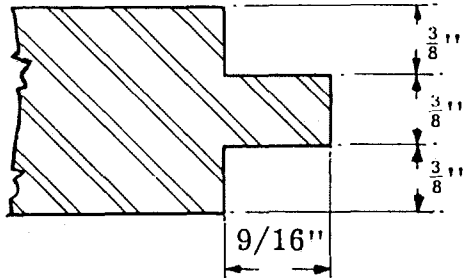

Maximum sizes double rebate

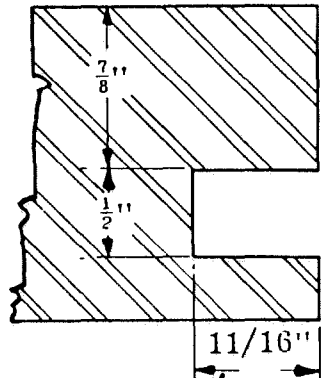

Maximum size of groove

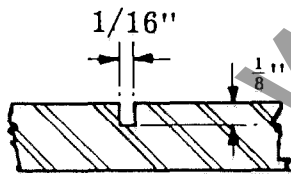

Smallest groove possible

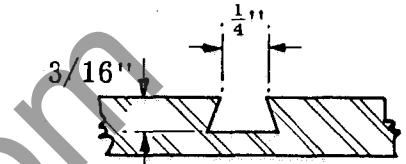
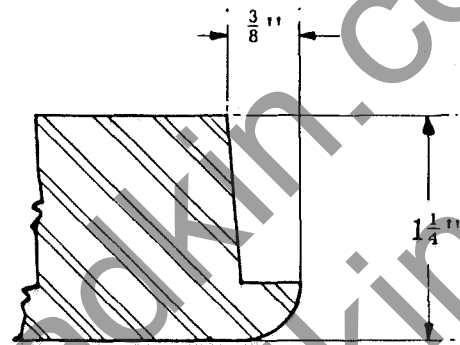

Maximum and minimum sizes of dovetail grooves

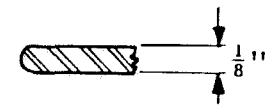
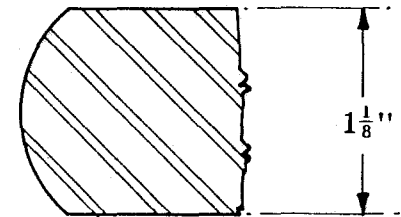

Maximum and minimum sizes of nosing (rounding) cutters Type 23.

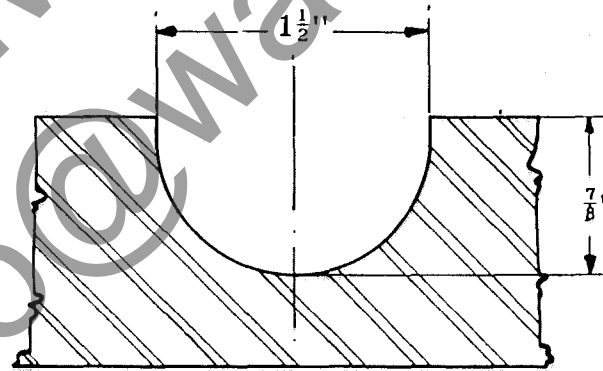

Maximum size of flute

A Spring Pressure Cramp can be fitted to the Router Head to ensure that hardwood components are pressed onto the jig.
Also preventing the component lifting off the spikes.
The spring pressure helps to provide accurate routing.

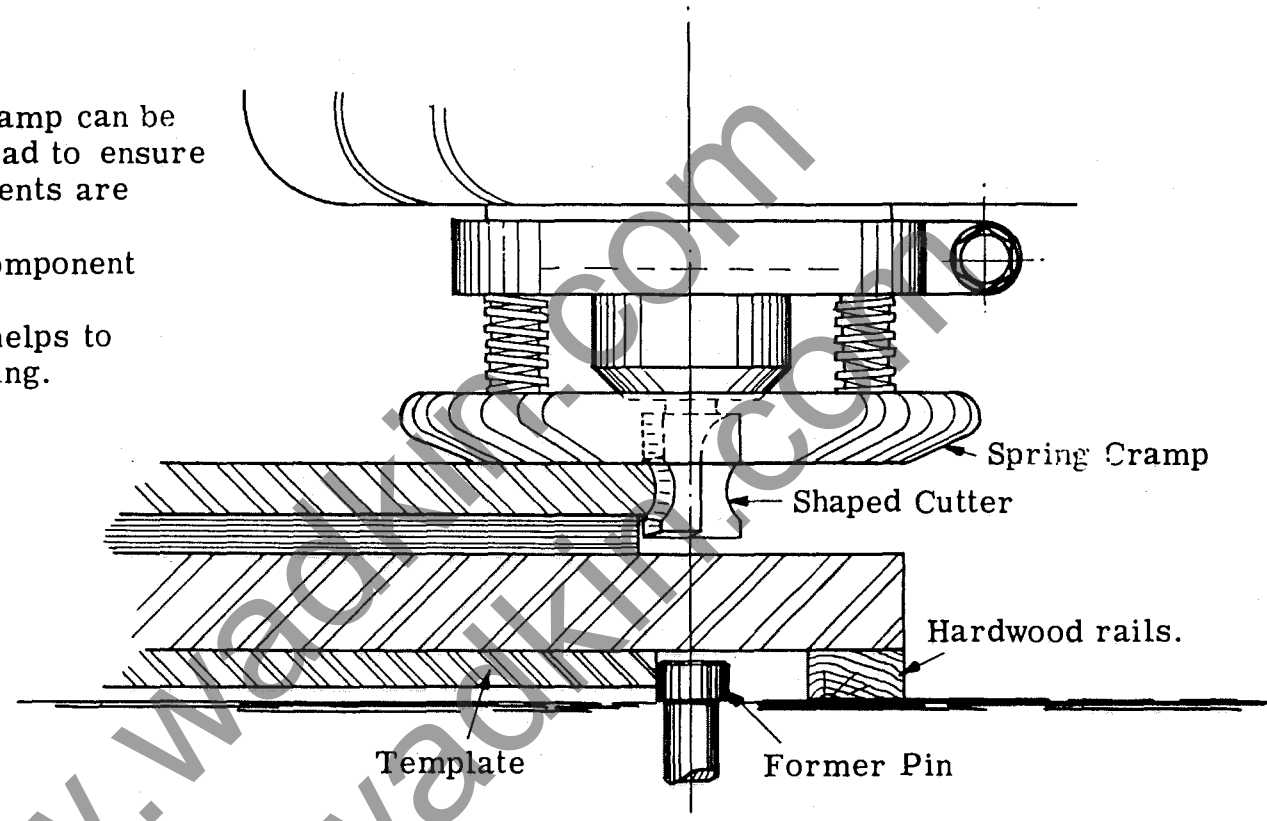

Applicable when routing thin plywood, veneers, plastics, and hardwood components which are held to the jig by spikes.

Double Edged Cutters - Panel Type 4.

Relief or clearance always increasing from the cutting edge

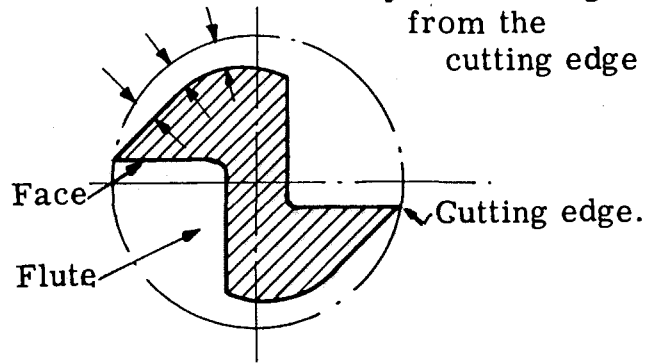

Cutter as sent out by Wadkin Ltd.

Single Edge Cutters-Spoon Type 1.

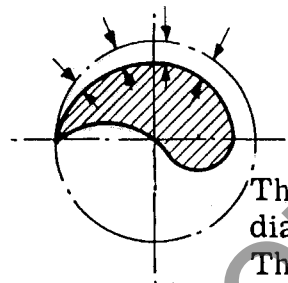

This type of cutter is used where cutter diameters of $\frac{3}{8}$ " or less are necessary. The relief or clearance of this type of cutter must never be ground free-hand. Always grind and hone spoon cutters in the flute, maintaining the original form as near as possible.

Hump behind cutting edge.

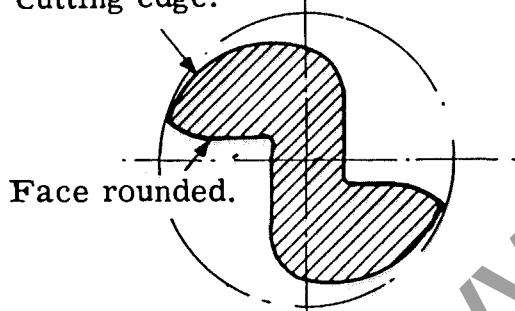

Face rounded.

Cutter incorrectly ground and honed.

Face ground straight.

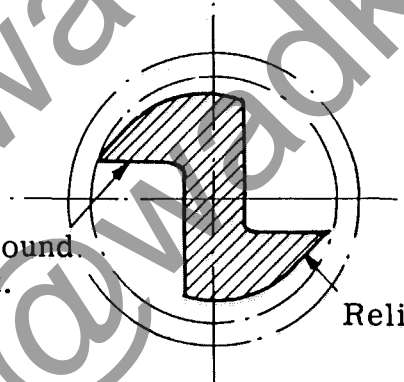

Cutter reground correctly.

Relief restored.



Incorrect grinding will result in cutter breakage and bad work.

CUTTER GRINDING

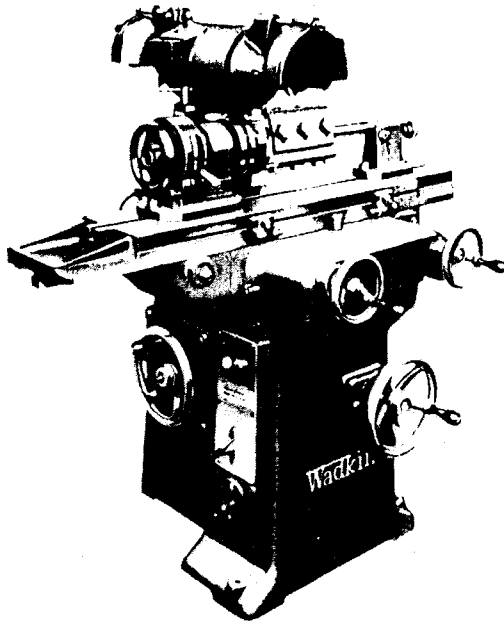

To obtain consistently good work from high speed routing it is essential that the cutters are kept sharpened and ground correctly. This can only be assured when suitable equipment is available. The ideal grinder for this purpose is the Universal Type N. H. shown left. Not only will this machine deal with all router cutters, but it is indispensable for maintaining every type of cutter equipment used in a woodworking plant, excluding long planer knives.

NOTE - Where a suitable grinder is already installed we can supply the set of fixtures for router cutters as used on this machine.

Where the amount of cutter grinding does not justify a Universal Grinder we recommend the N. U. type machine shown right. This machine has been specially designed for router cutters. It is self-contained and provided with a precision grinding spindle. Table has movement in three directions and is designed to take fixtures for handling all types of router cutters.

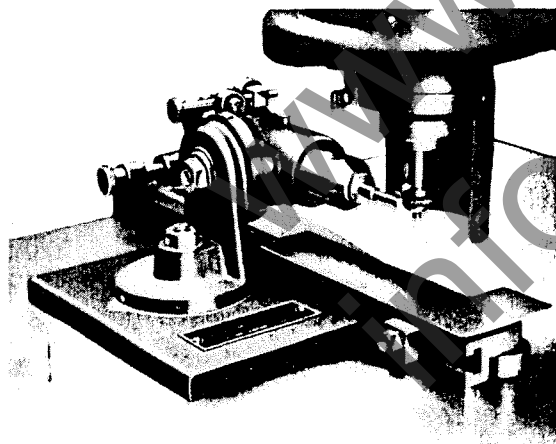

Whilst we strongly recommend the use of a separate grinder, where the number of cutters to be maintained does not justify either of the above machines, we can supply the fixture shown left for use on the Router itself. In this case it is essential to use the Router with speed 18,000 r. p. m., this lower speed being necessary for the grinding wheels.

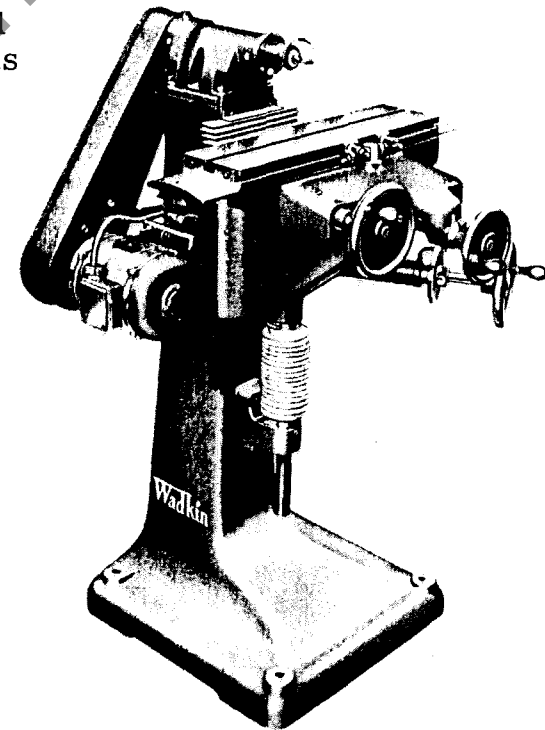

INSTRUCTIONS FOR GRINDING WADKIN ROUTER CUTTERS

A sharp and properly ground cutter is the key to good routing. It is important, therefore, that the operator should understand exactly what he is doing when sharpening cutters.

Detailed instructions in the grinding of all types of router cutters are given on the following pages, and if read carefully and the instructions carried out will ensure trouble free running and high production.

WOODWORKING CUTTERS.

CHOICE OF THE CORRECT CUTTER.

In order to get the best results from routing it is essential to use the proper cutter for each operation. Straight cutters from 1/16" diameter to 1 1/2" diameter are available in varying lengths. A wide range of shaped cutters can be supplied, also built-up cutters for tonguing and grooving, moulding, etc., circular cutterblocks and moulding blocks. Illustrations show some of the principal types in the range.

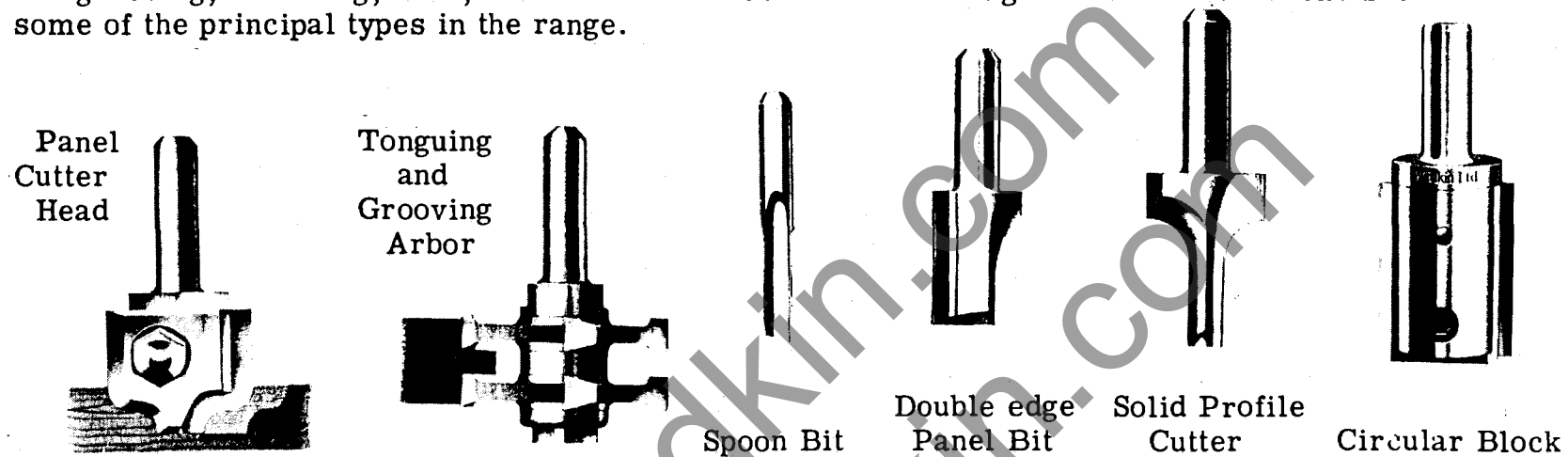

When in doubt, always consult Wadkin Ltd. for advice and recommendations. More information on cutter types can be obtained under the following References :-

ROUTER CUTTERS AND ACCESSORIES BOOKLET SECTION "J"

THE AIM OF CUTTER SHARPENING.

The primary object of cutter sharpening is to restore the cutting edge at the correct cutting angle and ensure correct clearance behind the cutting edge.

Relief or clearance.

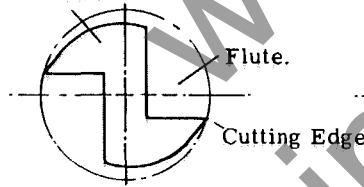

Correctly honed and ground cutter.

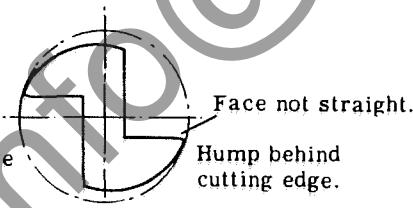

Incorrectly honed cutter.

Original diameter.

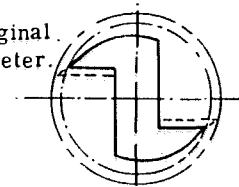

Worn cutter correctly ground and honed.

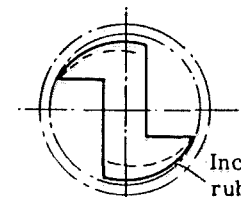

Dotted line indicates necessary grinding to restore cutting edges.

THE IMPORTANCE OF MACHINE GRINDING.

The key to high quality routing is a cutter with clean sharp edges and smooth continuous relief.

In order to maintain the correct cutting angle and clearance, machine grinding is essential.

Experience has shown that free-hand grinding does not give the clean smooth edge essential for good cutting, and the result is nothing like the life of a machine ground cutter. Another important point is that it is almost impossible to grind equal amounts from both edges free-hand.

Mechanical grinding ensures that both edges of a cutter are identical, also the minimum amount

of metal is removed at each regrind, thus making sure of longer life from a cutter than when most carefully free-hand ground.

most carefully free-hand ground.

GRINDING MACHINE, TYPE N. U.

This is the Grinding Machine generally supplied for grinding router cutters (see illustration on Page 42). It has a spindle speed of 4,750 r. p. m. and is provided with rise and fall, and also

traverse movement to the table. With the aid of the three attachments shown overleaf, most

types of cutters for both metal and wood routing can be dealt with. The class of work being done

will dictate the attachments needed, but for wood cutters the S. F. A. attachment is essential,

and the P. R. F. is very useful for regrinding the relief on straight panel cutters. For sheet

dural, alclad and brass the D. G. A. and P. R. F. attachments are essential.

Where an existing Tool Room Grinder of suitable type and having a speed of not less than 5000 r. p. m. is available, the grinding attachments only are needed.

In such cases the user would need to make a spindle extension arbor to suit his machine.

GRINDING ATTACHMENTS

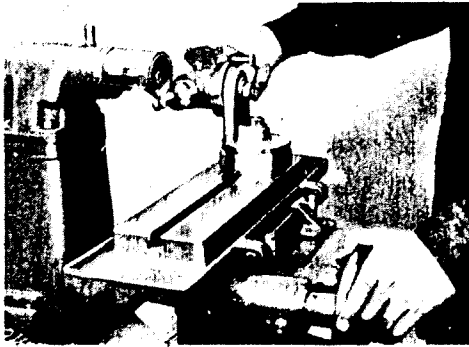

ATTACHMENT S. F. A.

to be used for grinding straight fluted cutters of all types, also ending up panel cutters and Spoon Bits.

This attachment will generally be used for profiling cutters and spoon bits. It is also suitable for tungsten carbide cutters.

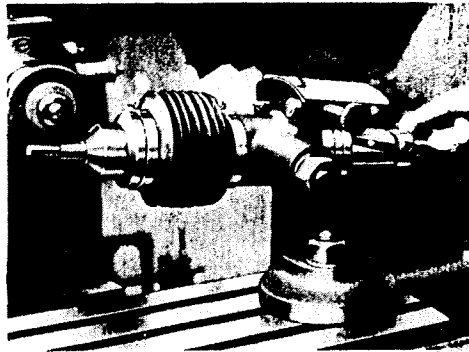

ATTACHMENT D. G. A.

to be used for grinding the flutes (spiral or straight) of all alclad or dural cutters used on SHEET WORK.

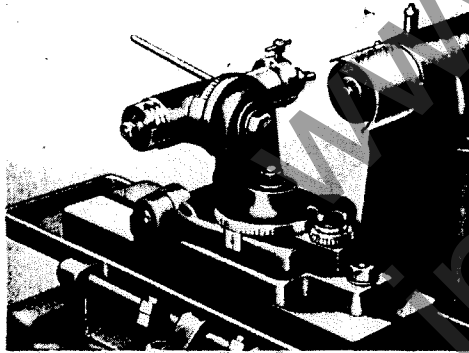

ATTACHMENT P. R. F.

to be used for regrinding the eccentric relief on panel cutters; suitable for dural, alclad and brass cutters, after loss of clearance due to continuous honing.

Grinding wheels supplied with GRINDING ATTACHMENTS.

FOR ATTACHMENT S. F. A. ONLY



139

2" diameter
 $\frac{3}{8}$ " FLAT face
 $\frac{3}{8}$ " Bore



140

2 $\frac{1}{4}$ " diameter
1" CUP
 $\frac{3}{8}$ " Bore

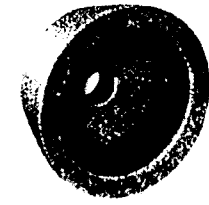

141

2 $\frac{1}{4}$ " diameter
1" DISH
 $\frac{3}{8}$ " Bore

FOR ATTACHMENT D. G. A. and S. F. A.

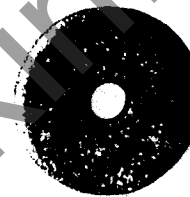

137

2" diameter
3/16" ROUND edge
 $\frac{3}{8}$ " Bore

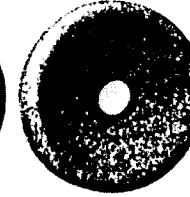

138

2" diameter
 $\frac{1}{4}$ " ROUND edge
 $\frac{3}{8}$ " Bore

FOR ATTACHMENT S. F. A.

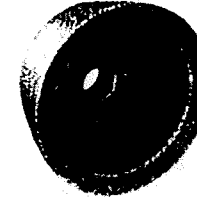

86R Rougher

87R Finisher

These wheels are used for grinding chipped edges of Tungsten Carbide Cutters. Both are 2 $\frac{1}{4}$ " diameter, 1" dish, $\frac{3}{8}$ " bore.

FOR ATTACHMENT P. R. F.

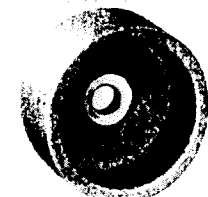

146

2 $\frac{1}{4}$ " diameter
1" CUP
 $\frac{3}{8}$ " Bore

LAPS FOR TUNGSTEN CARBIDE
TIPPED ROUTER CUTTERS.

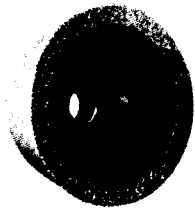

145

Diamond lap wheel for use on Attachment S. F. A. and used for lap finishing Tungsten Carbide Tipped Cutters after regrinding with wheels 86R and 87R.

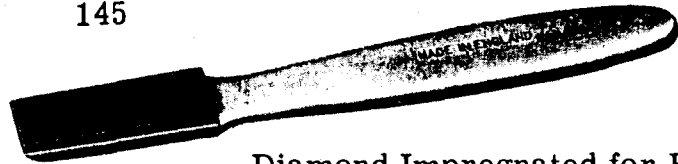

Diamond Impregnated for Hand Lap honing Tungsten Carbide Tipped Cutters. Also a similar hone of solid material in fine and medium grain can be supplied.

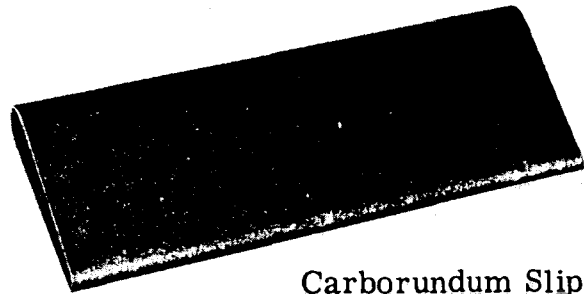

Carborundum Slip Stones
for High Speed Steel Router Cutters
No. 183. $4\frac{1}{2}'' \times 1\frac{3}{4}'' \times \frac{1}{2}''$ - $3/16''$
No. 177. $4\frac{1}{2}'' \times 1\frac{3}{4}'' \times \frac{1}{4}''$ - $1/16''$

WHEEL DRESSER DIAMOND. PART NO. P. R. F. 37.

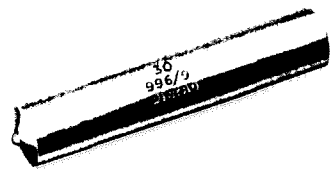

used for dressing all types of grinding wheels, excepting the Diamond Lap Wheel, No. 145.

REGRINDING STRAIGHT FLUTED CUTTERS OF
ALL TYPES, ON ATTACHMENT S. F. A.

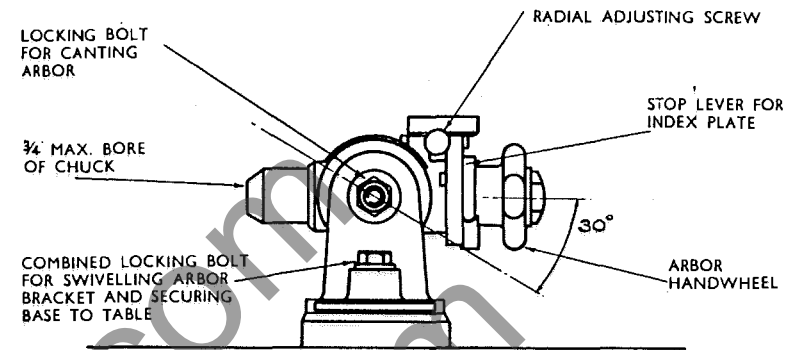

TYPES OF CUTTERS MOST COMMONLY GROUND
ON THIS ATTACHMENT :-

SPOON BITS. Use grinding wheels Nos. 137 and 138.



After grinding the flute, it will be necessary to stone a flat on the cutting edge of this type of cutter to obtain more clearance. The outside diameter should not be ground.

PANEL ROUTER CUTTERS
OR
SOLID SHAPED CUTTERS

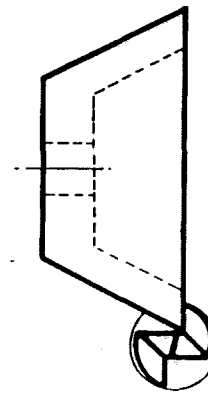

Use grinding wheels Nos. 140 and 141. After setting up as described opposite both flutes should be ground at the one setting.

After several regrinds of the flutes it becomes necessary on this type of cutter to give more clearance on the back of the cutting edge. (See pages 48 and 49.)

TO SET UP FOR GRINDING FLUTES.

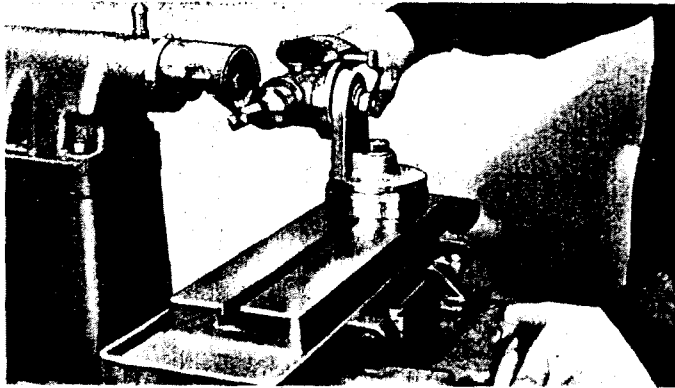

First bring the cutter flute into correct relation with wheel. Adjust the stop on machine table to suit length of flute to be ground. Use table movement to grind the flute taking light cuts. To put on any cut use the radial adjusting screw, thus maintaining a correct cutting angle. Both flutes should be ground after each adjustment to ensure that each is ground identically.

TO SET UP FOR GRINDING THE END OF THE CUTTER.

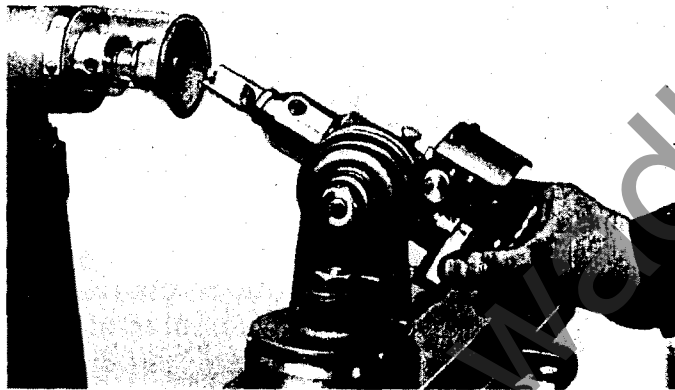

First turn attachment round at right angles to grinding wheel and lock up. Bring cutter into correct relation with wheel and adjust stop. Take light cuts by using table movement. The remaining face can be brought into a similar position by using index plate.

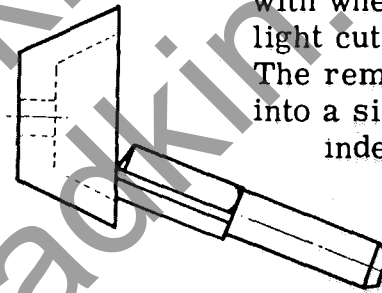

Use grinding wheels 140 and 141.

PERIPHERAL RELIEVING OR REGRINDING CLEARANCE OF PANEL CUTTERS ON ATTACHMENT S. F. A.

The best results on relief grinding are obtained by using the attachment P. R. F., as described on pages 49 to 53.

This method is illustrated for operators who have the S. F. A. Attachment only, but it should be stressed that the results obtained will not be as good as with the P. R. F.

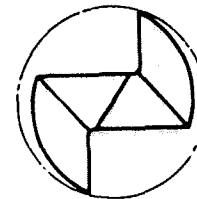

Fig. 1
Shows a new panel cutter with plenty of clearance.

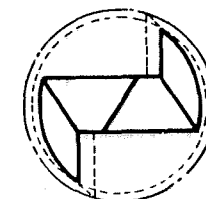
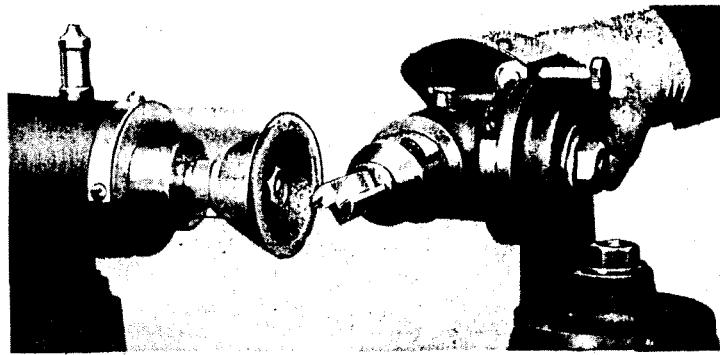

Fig. 2
Shows the same cutter after several regrinds with no clearance.

PERIPHERAL RELIEVING ON ATTACHMENT S. F. A.



Cutter is moved across the wheel by table movement as for grinding the flutes. Take light cuts.

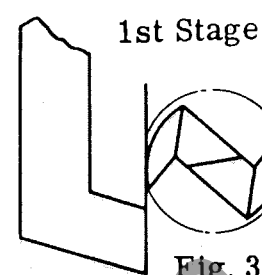

Fig. 3

Use wheel No. 140 or 141

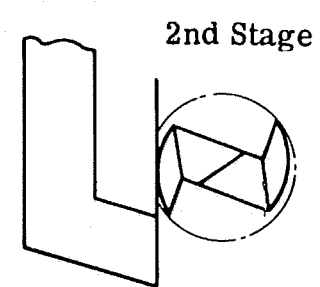

Fig. 4

Using same wheel.

GRINDING OF SHAPED CUTTERS TYPE NOS. 9, 11, 12, 32.

Shaped cutters must only be ground in the flute and must never be ground on the straight relief, unless the shape or profile of the cutter is being altered. This operation is done on the S. F. A. Attachment, using wheel No. 141. The method is illustrated right and described on page 48.



PERIPHERAL RELIEVING OF PANEL CUTTERS ON ATTACHMENT P. R. F., ALSO SUITABLE FOR RELIEVING OF TWO-EDGED CUTTERS FOR SHEET DURAL, ALCLAD AND BRASS.

This Attachment, mounted on our N. U. Grinder has been designed to obviate the poor results obtained when operating Routing Machines due to the outside relief of cutters being improperly honed, and in some cases, hand ground. It consists of a base plate, on which is pivoted a platen carrying a swivelling bracket, on which in turn is carried the spindle head which can also swivel. Both the swivelling units are graduated and the control knob for pivoting has also a graduated dial. The work spindle is on the eccentric principle, provision being made to vary the eccentricity (or radius of relief).

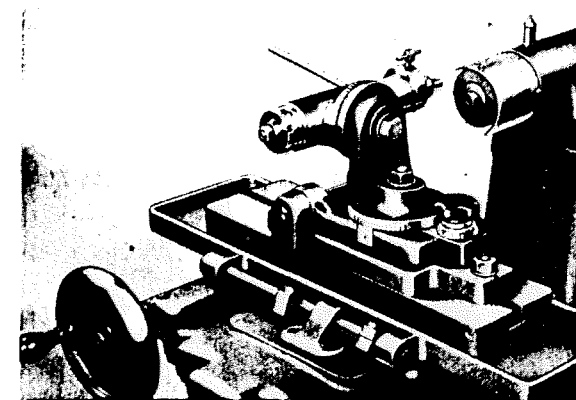

GRINDING OF GROOVING CUTTERS TYPES 41 - 53.

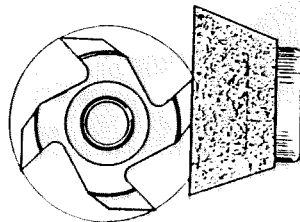

These cutters must never be ground in the flutes because of the loss of width which would quickly result, due to side relief of cutting edges. Resharpener these cutters by grinding on the outside face, using the S. F. A. Attachment.

Grinding of cutters for Flat Knife Chuck No. 50, Expanding Cutterhead No. 51, Panel Cutterhead No. 52, Circular Block No. 55.

For resharpening these cutters it is recommended that the knives be removed from the block and ground freehand on a moulding iron grinder.

For holding the cutters, bushes $\frac{3}{8}$ " and $\frac{1}{2}$ " bore are provided; these have two lines engraved at 180° , each line in turn being brought into alignment with a zero line on the spindle nose, thus enabling both edges of the cutter to be ground at one setting. An approximate position to place the cutter radially is also indicated by another line on the nose of each bush, one of the cutter edges being placed opposite this; this position can only be approximate as some cutters require more drastic relief (or clearance) than others.

This variation of clearance must not be confused with varying eccentricity or (radius of relief). The bushes are gripped in a split body and can be changed quickly.

A holder with diamond for trueing the wheel is also provided and fits the spindle nose the same as the cutter bushes. Arrangements are made to hold the work spindle radially when using the diamond. Part No. of this diamond is P. R. F. 37.

It is absolutely essential to true the grinding wheel with a diamond. A special fine grain wheel No. 146 is supplied with this attachment.

TO SET UP FOR GRINDING.

First set both swivelling bracket and spindle head with graduations at zero; then, with the vertical movement of the machine table, bring the attachment spindle to the same height approximately as the grinding wheel spindle (if anything the centre of the attachment spindle should be a little higher than the centre of grinding wheel spindle). Now insert cutter with one edge opposite the line on the NOSE of the cutter bush and tighten firmly with the set screw; then set cutter bush with one graduation in line with zero line on spindle nose and tighten with tee headed screw shown in right hand in Fig. 2. Fig. 3 shows cutter setting line on nose of bush and also one of the bush setting lines correctly set on the zero line of spindle nose; this photograph also shows the actual grinding operation.



Fig. 2

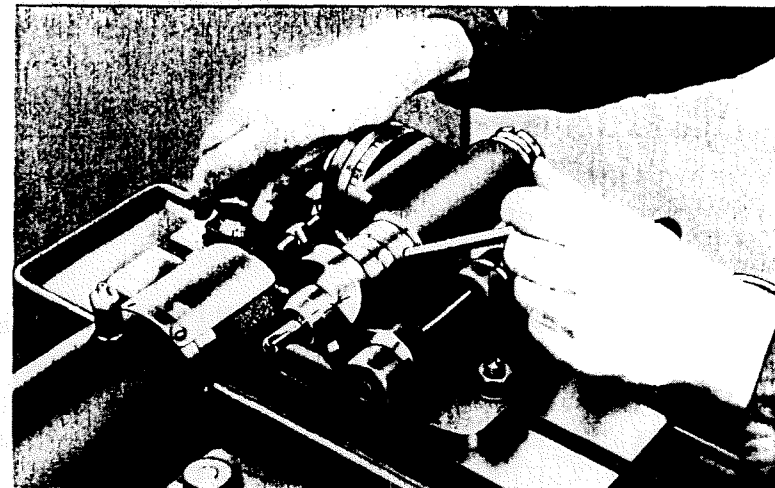

Fig. 3

It will not be necessary as a general rule to move the spindle head away from zero, but the swivelling bracket (which has its base on the platen) will require moving a little off zero for the spiral fluted cutters, otherwise, due to the spiral angle, the grinding operation will produce a taper cutter.

For right hand spiral cutters move the bracket zero line a little to the left and vice versa for left hand spiral cutter. Fig. 4 shows the zero line on bracket moved out of line as required for a right hand spiral cutter.

TO GRIND A CUTTER.

Unscrew control knob shown in right hand on Fig. 4 to give about $\frac{3}{8}$ " opening between the platen and base plate. Bring the table up until the surface of the cutter to be ground is $\frac{1}{16}$ " away from the grinding wheel; then move table stop indicated by left hand up to stop bracket and tighten up.

Start machine, and by the control lever rotate one edge of the cutter to and fro, bringing the cutter into contact with the grinding wheel by turning the control knob clockwise.

Take care not to take the control lever too far over or the opposite cutting edge will come into contact with the wheel and be damaged.

Now bring the table and fixture away from the wheel and note the number of the graduation on the control knob dial which is opposite the zero line on the platen.

Unscrew control knob half to three quarters of a turn, unscrew tee headed screw shown in right hand on Fig. 2 and turn cutter holder round until the arrow on opposite side is in line with zero mark on spindle nose; left hand indicates this being done (do not release cutter), then tighten up tee headed screw, move table up to stop and proceed as before until dial on control knob comes to the same number as before. For metal routing cutters proceed to remove a further .010", to cut back one edge, by using in feed of machine table. See Page 57.

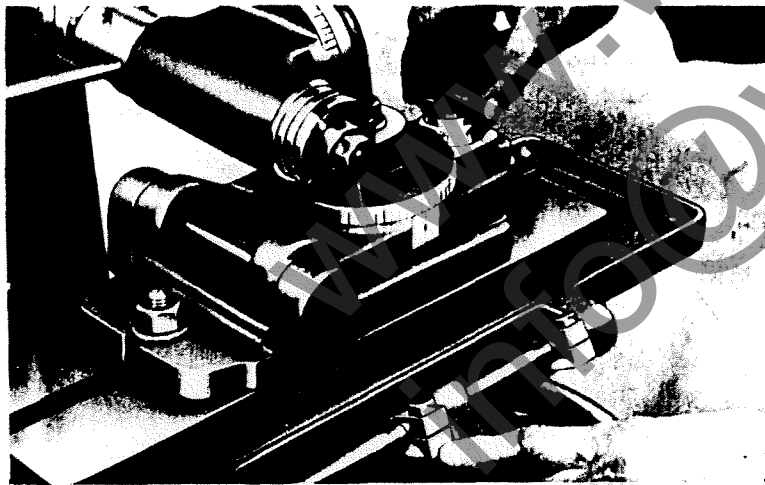

Fig. 4

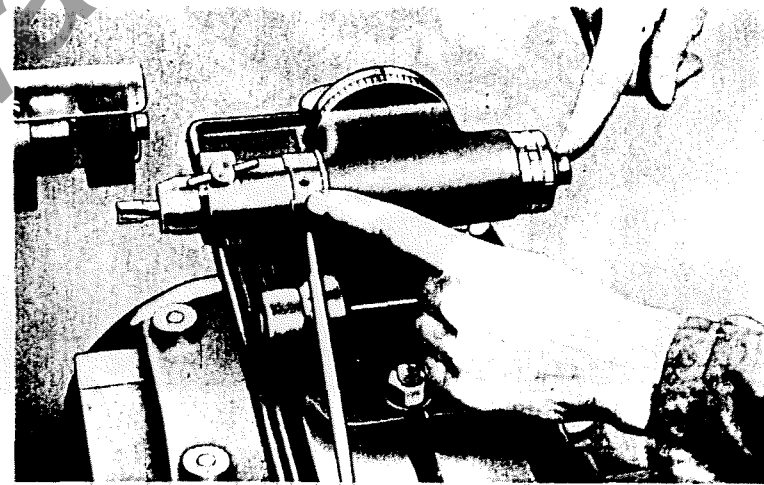

Fig. 5

For cutters of greater length than the face of the wheel, repeat the operation with the table cross traverse adjusted to cover the remaining length of the cutter edge. When finishing, pass the cutter over the grinding wheel once or twice, moving the cross traverse slide sufficiently to cover the whole length of the cutting edge being relieved. On short cutters move the cross traverse a little each way to improve the surface finish.

Fig. 5 shows how the eccentricity (or radius of relief) is varied.

The spindle nose has an initial amount of eccentricity which can be varied as follows :-

Ease hexagon nut indicated by right hand, but do not slacken it right off; slacken off the small screw indicated by left hand, say a quarter of a turn, and tighten the one on the opposite side; this increases the eccentricity. To decrease the eccentricity slacken the screw on the opposite side and tighten the one indicated by left hand; then re-tighten the nut indicated by right hand. On no account try to adjust without easing the hexagon nut and be sure to re-tighten.

The amount of eccentricity required and the exact position to set the cutter are dependent on conditions and must be left to the operator who will find these adjustments quite easy after a little experience.

Fig. 6 shows the split chuck and the simplicity of changing cutter bushes or inserting the diamond holder. All that is necessary is to release the tee headed screw and draw the bush out; insert another, pushing it right up to the shoulder; bring the graduated line opposite zero line on the spindle nose and re-tighten the tee headed screw.



See that bushes and the base of the split chuck are perfectly clean and free from grit.

Fig. 6

TO DRESS THE WHEEL.

Fix clip onto operating handle as shown by right hand in Fig. 7, then insert the diamond holder in the spindle nose with the diamond inclined to point a little below centre (this is important) and follow the same procedure as for grinding cutters (see Page 51), using the cross slide of machine to pass the diamond across the periphery of the wheel and the control knob to regulate the cut as shown in Fig. 8.

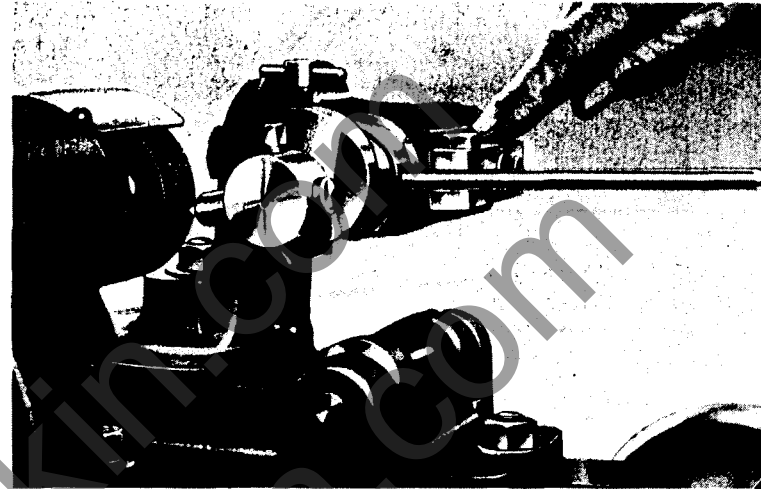

Fig. 7

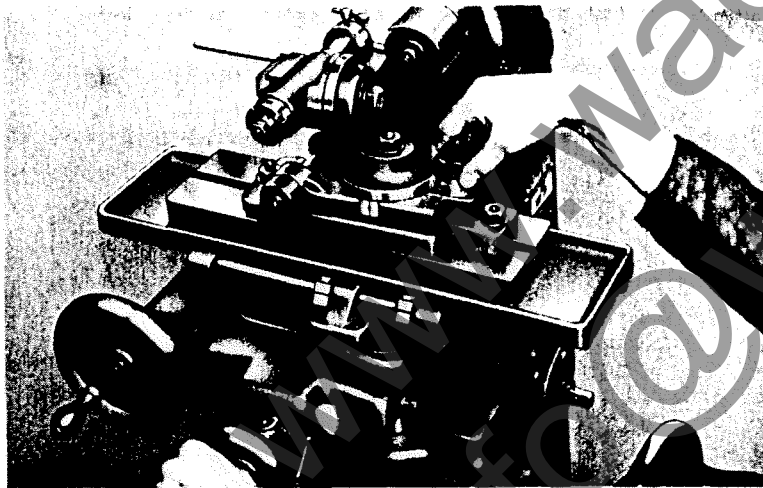

Fig. 8

See that the table stop is tight, only take **LIGHT** cuts and pass the diamond over the wheel slowly and with a continuous regular motion. When mounting the wheel on machine spindle place it with the recessed side towards the machine as shown in Fig. 2.

Frequent dressing of the grinding wheel is not necessary. Considerable quantities of cutters should be ground between dressings and after the initial truing of a new wheel subsequent dressings should be of the lightest character.

STONING OF CUTTERS

THE RIGHT AND WRONG WAY OF STONING

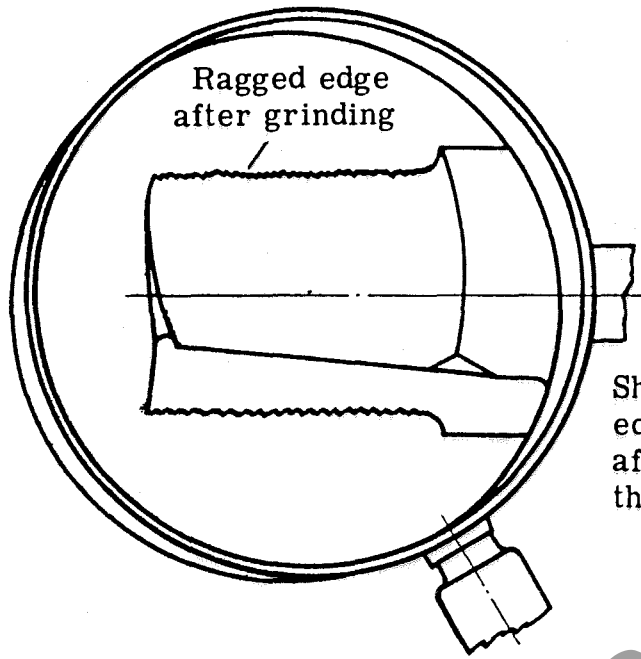

Shows ragged edge of cutter after grinding the flutes.

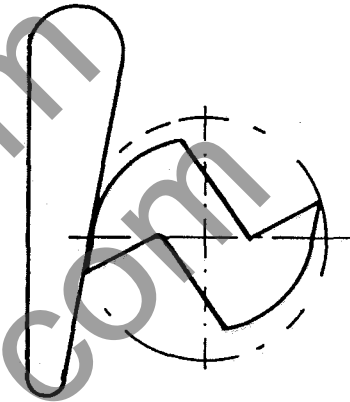

THE RIGHT WAY - Cutting edge is on the outside periphery of cutter track, with back of cutter clearing the job.

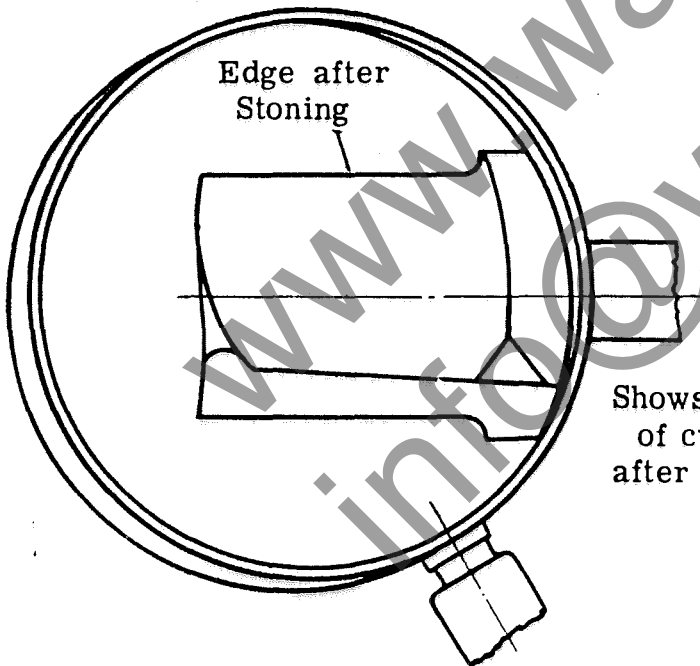

Shows edge of cutter after Stoning.

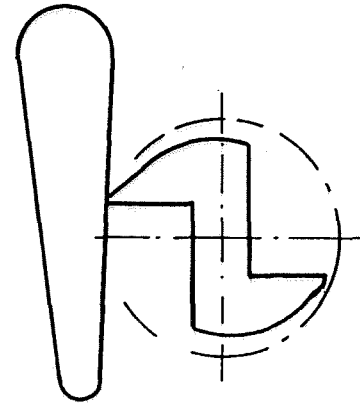

THE WRONG WAY - Back of cutter forms outside periphery of cutter, with the result that rubbing of the back on the job occurs.

STONING OF CUTTERS

After grinding, the cutter must be stoned up before using to remove the ragged edge. This is done by using a No. 183 or 177 Carborundum slip stone dipped in paraffin and applied to the edge of the cutter as shown below. (Stones are illustrated on Page 47). Correct stoning can only be achieved by practice, but most operators have no difficulty with this operation after a few weeks experience. A reliable guide as to whether the cutter has been properly stoned will be that the job will almost feed itself, instead of requiring force in feeding past the cutter. In addition to stoning after grinding, the cutter will need restoning between regrinds. The length of time the cutter will retain its edge will depend on the material, and may vary between half an hour and two hours or more. Here again, the effort required to feed the work is the best indication of the condition of the cutter and whether stoning is required. Stoning for half a minute should be sufficient and the cutter should stand between four and eight restonings between regrinds, depending on the skill of the operator.



TYPICAL QUESTIONS AND ANSWERS ON WOOD ROUTER CUTTER SHARPENING.

Is a cutter as despatched by the makers ready for use?

No. It requires honing or stoning before being used. The cutters are sent out as they leave the Grinding Machine. They are not stoned up at our Works as the edge may be damaged in transit.

Is the use of a slip stone necessary on router cutters?

Yes. All cutters should be honed before using on the Router. The sharper the cutter the better the finish and the faster the feed.

What sort of slip stone should be used, and what methods should be employed?

See recommendations as regards stones on Page 47, and the method of stoning, Pages 54-55.

How often should the cutter be honed?

This depends on the timber being cut. Stringy timber may require a stone on the cutter every 20 minutes, while on clean straight grain wood the cutter may run for an hour.

When does a cutter need sharpening?

When the work is difficult to push past the cutter, or when the finish is not clean and smooth, the two characteristics generally go together. When the cutter is sharp, the work will almost feed itself.

What determines whether a panel cutter should be ground in the flute or on the relief?

The general practice is to grind in the flute, as shown on Page 48, and continue to do so until the relief or clearance, shown on Page 44, becomes insufficient. Then regrind the relief as shown on Pages 49 to 52.

Is there any means of truing the emery wheels on the Cutter Grinder?

Yes. The diamond mounted in a steel holder, $\frac{1}{2}$ " diameter, is shown on Page 47. The method for truing wheel No. 146 is shown on Page 53. When truing the face of the wheel No. 141, mount the diamond in place of the cutter on the attachment S. F. A. shown centre of Page 48, and proceed as described on Page 53.

Is machine grinding of cutters essential?

Yes. To get good work, and economy of cutter life. See Page 45.

CUTTERS FOR NON-FERROUS SHEETS.

Wadkin cutters are made in two ranges, one having a profile suitable for cutting Dural and Brass, and the other suitable for cutting Aluminium and Alclad. In general, these cutters are quite suitable for use as sent out, without modification of the profile, but some operators claim to obtain improved performance by slightly modifying the profile of the cutter to suit the particular specification of metal which they are cutting.

These modifications may be regarded as refinements and should not be attempted until the operator has become quite proficient in the use of the machine.

The types of cutters available are shown on a list which is issued and revised from time to time, and can be obtained on enquiry from us. All Wadkin cutters are numbered and it is advisable to quote the reference number when ordering or referring to specific types and sizes of cutters.

For cutting out from sheet the best size to use is a $\frac{3}{8}$ " diameter double-edged cutter, having a $\frac{1}{2}$ " diameter shank. It is possible to use a $\frac{1}{4}$ " cutter where $\frac{1}{8}$ " internal radii are essential or $\frac{1}{2}$ " diameter, if required.

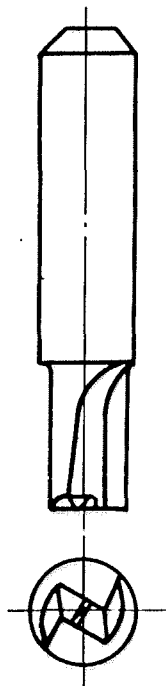

Typical cutter for profiling.

CUTTERS FOR PROFILING CASTINGS STAMPINGS AND NON-FERROUS METAL FACED PLYWOOD, ETC.

For this class of work we recommend an entirely different range of cutters from those used for sheet cutting. In general, these cutters are Z section with straight flutes, but it is advisable to consult us before ordering cutters, to ensure that the most suitable type is used for the particular metal to be cut and for the amount of metal to be removed.

SIZES OF CUTTER SHANKS.

All cutter shanks on the cutters we supply are held to a limit of $\pm .0005$ " and $-.0005$ ", i. e. a tolerance of one thousandth of an inch, but whatever the diameter it is most important that the shank is parallel. A cutter shank over $.0005$ " taper will not give satisfactory results.

SMALL CUTTERS FOR SPECIAL WORK SUCH AS GROOVING.

When using small cutters, such as $\frac{1}{8}$ " or $\frac{3}{16}$ " diameter, we recommend ordinary wood cutting spoon bits, and these are quite satisfactory. Always shorten the cutting blade as much as possible to avoid breakage. This is best done by the user himself as the cutters can then be shortened to suit his own type of work.

HOW TO TELL WHEN A METAL WORKING CUTTER NEEDS RE-GRINDING.

The first thing a routing machine operator should know is how to tell when the cutter is sharp and working correctly. The answer is that when the cutter is right, the chips will leave the cutter bright and curly, and the feed will be so easy that the job almost feeds itself. When these conditions exist the cutter will have a long life between grinds.

If the cutter is incorrectly ground, the chips will come off in straight shreds, and an excessive amount of force will be needed to push the job past the cutter. Good work is out of the question under such conditions, and there is always the danger of pushing the end off the cutter.

If the cutter is not working correctly, stop the machine immediately and find out why.

To ensure the maximum life of the cutter, and at the same time obtain free cutting, it is essential that the cutter is kept efficiently lubricated. Always use a lubricant consisting of a mixture of paraffin and lard oil. The simplest method of application is by brushing the lubricant on to each blank before clamping. The lubricant need only be applied on the sheets in the track of the cutter.

THE IMPORTANCE OF MACHINE GRINDING.

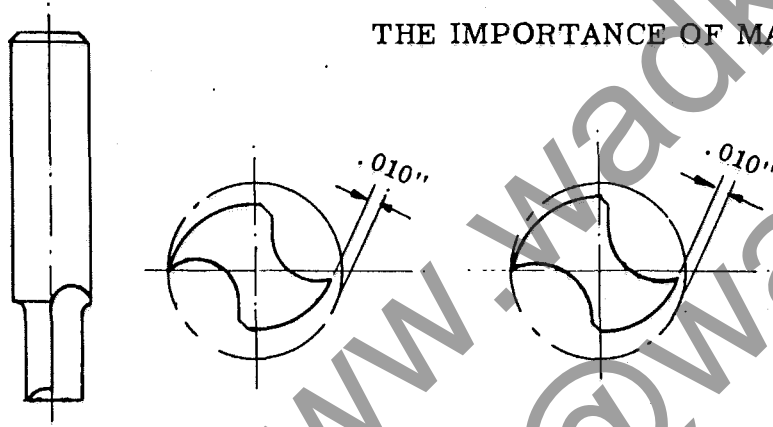

All metal cutting router cutters have one edge ground back .010. This is done in the formed relief grinding so that the normal re-grinding in the flutes of the cutter will not be affected.

In order to preserve the cutting diameter resharpener is done by regrinding the two spiral flutes equally. Experience has shown that free hand grinding does not give the clean smooth throat essential for chip clearance and good cutting and, in consequence, gives nothing like the life between grinds that a machine-ground cutter gives.

Another important point is that it is almost impossible to grind equal amounts from both edges free hand.

By resharpener by mechanical means, not only is accurate grinding ensured, with both edges of the cutter ground identically, but the minimum amount is removed from the cutter at each regrind, ensuring a longer life than is possible by the most careful free hand grinding.

For details of the recommended grinding machine and attachments, see pages 42, 45 and 46.

Wadkin metal working router cutters (except special purpose cutters) are supplied with two spiral cutting edges, as shown in the sketch below.

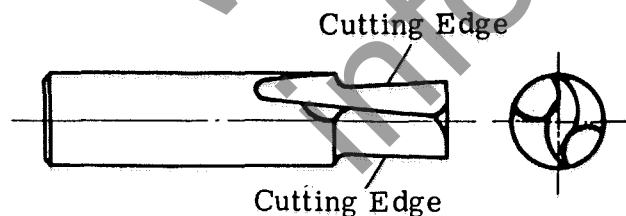

REGRINDING STRAIGHT OR SPIRAL FLUTED CUTTERS FOR NON-FERROUS METAL SHEETWORK ON

ATTACHMENT D. G. A.

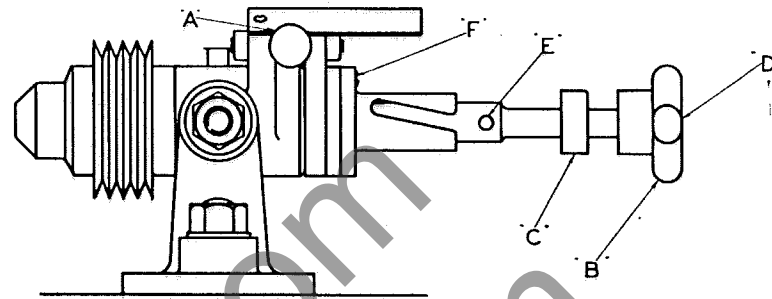

TO SET UP FOR GRINDING STRAIGHT FLUTES.

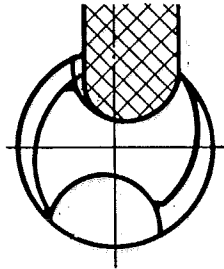

Use grinding wheels up, as this will alter the contour of the flute, thus varying the cutting angle. Nos. 137 or 138.

The cutter is placed in the spindle nose and the attachment adjusted to bring the flute into correct relation with the wheel, i e., parallel with the table slots. The table and cross slide should then be locked, and the rise and fall of the table and the radial adjustment screw "A" only, should be used during the subsequent grinding operation.

The cross slide of the table must not be used to put on cut after once setting

TO SET UP FOR GRINDING SPIRAL FLUTES ON METAL CUTTERS.

The set up and method of grinding in this case is identical with that for the straight fluted cutters except that it is necessary to set over the head as shown below to bring the flute into the correct parallel relation with the table slots.

It will also be necessary to change the slotted sleeve. To do this first remove the handwheel B and collar C by loosening grub screws with the special key provided. Slacken off grub screw D in the end of the spindle and withdraw guide pin E. Unscrew the three countersunk screws F from the sleeve. The sleeve is now free to be withdrawn from the spindle.

PLAN VIEW SHOWING HEAD SET OVER FOR GRINDING SPIRAL FLUTES.

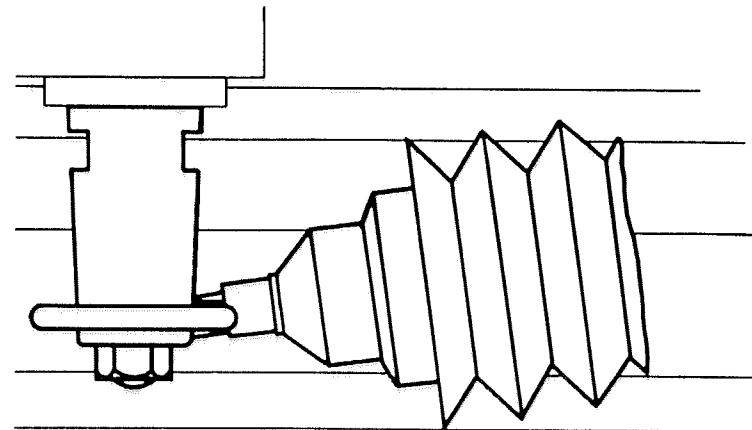

METHOD OF GRINDING FLUTES ON THE ATTACHMENT D. G. A.

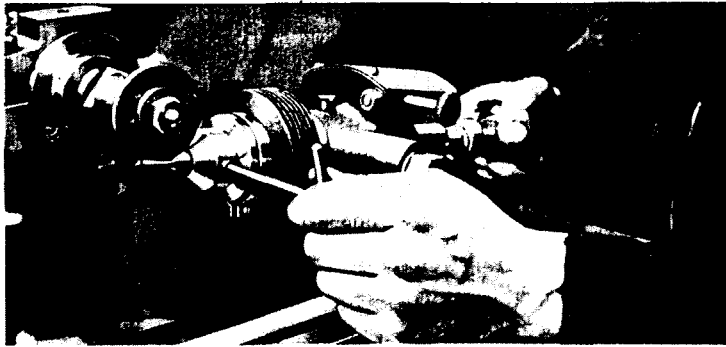

- 1 Bring the cutter into the correct relation with the grinding wheel by adjusting the table slides. Lock table slides and lock cutter as shown above.

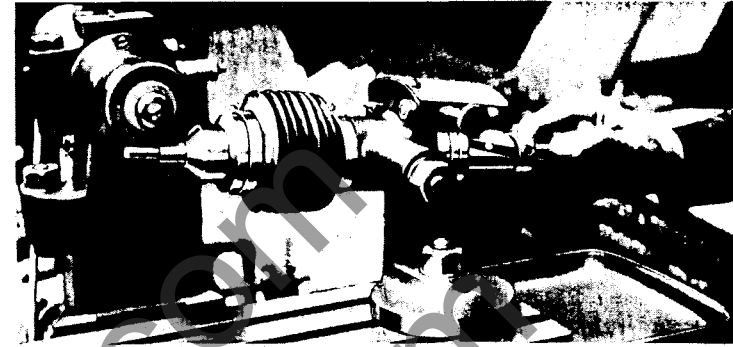

- 2 The grinding is done by sliding the cutter past the wheel, taking care to set the stop collar near the operating handle. This motion is controlled by a grooved sleeve. Raise the table until the wheel makes contact, and draw spindle right back after making each stroke. Turn through 180° , then grind the other flute.

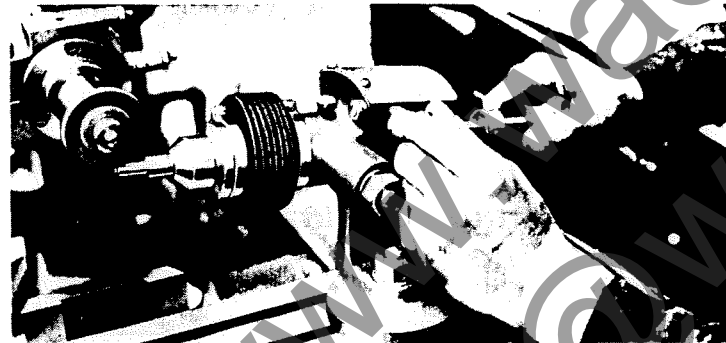

- 3 The cutting edge of the cutter is adjusted relative to the grinding wheel by turning the small screw as shown above. Both flutes should be ground at the one setting. If after examination both edges have not been cleaned up, put on more radial cut and repeat the grinding operation. Both flutes should be ground after each adjustment to ensure that both flutes are ground identically.

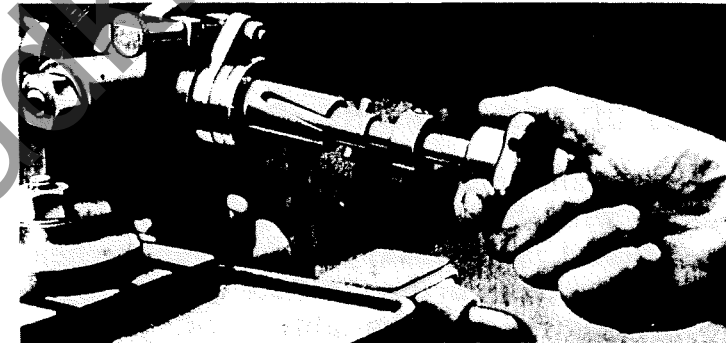

- 4 After grinding one flute of the cutter, the spindle is drawn back to bring the diagonal pin clear of the bush, as shown below. It is then rotated half a turn to bring the opposite flute into position, when the pin can be re-inserted in the bush.

TYPICAL QUESTIONS AND ANSWERS ON METAL CUTTER SHARPENING.

Is a cutter received from the Stores ready for use?

No. It requires honing or stoning before use. The cutters are sent out as they leave the Grinding Machine. They are not stoned up at our Works, as the cutting edges would be damaged in transit.

Is it permissible to use an oil stone on the outside of the cutters when dull?

This is the essence of routing and the key to high performance. As soon as the cutter begins to drag, stop the machine and hone up the cutter on the outer edges until they are sharp. This can easily be done in half a minute and the method is illustrated on pages 54 and 55.

How often should a metal working cutter be stoned?

About every hour. On hard material it may be every half hour. On some soft materials every two hours, but on aluminium and alclad sheets it pays to keep the cutter sharp to prevent packing on the cutter.

How many times should a cutter be stoned between regrinds?

A cutter should stand four to eight stonings depending on the skill of the operator.

What stone should be used and should it be used dry?

A No. 183 Carborundum Slip Stone. Dip the stone in oil and paraffin to give the best results.

Should the cutters be used dry on metal?

No. Always use a lubricant consisting of paraffin and lard oil, mixed and applied to the sheets by brush before commencing to cut. The paraffin is only a thinner to help to spread the lard oil, and only enough for the purpose should be used. Excessive paraffin causes a blue smoke when cutting.

What causes metal chips to pack on the cutter?

Generally, blunt cutters. The wrong shape of cutter, especially on aluminium and alclad sheets will cause it, also a lack of lubricant.

What causes chips to pack in the guide bush?

Blunt cutters. They make shreds of swarf which work up into the bush and weld to the shank. If the cutter is correct the large curly chips cannot possibly get into the small clearance between cutter and guide bush.

What causes shudder when cutting?

The cutter has not been stoned. The rough saw edge left by the grinding wheel causes it. To cure it, stone the cutter.

TYPICAL QUESTIONS AND ANSWERS - Continued.

Can the loss of diameter due to cutter wear be compensated for?

Yes. All Fixed Head Routing Machines are now sent out with a range of graded pins :- .005", .010", .015", .020" on all sizes. On the Radial Machine, undersized guide bushes can be supplied.

What is the feed speed on the Router?

Feed as fast as the cutter will take it. If the cutter is sharp the job will almost feed itself and will only require guiding. If the job needs pushing the cutter is not sharp. On metal, a good speed on straight work is 4 inches per second. On intricate shapes, it is impossible to feed at this speed, and the limitation is the speed at which the operator can manipulate the job, generally, 1 to 2 inches per second.

Can sheet steel be routed?

No, only non-ferrous metals such as Alclad, Dural, Aluminium, Brass, Copper, Lead. Not Bronzes, Zincs or Tin.

TUNGSTEN CARBIDE TIPPED ROUTER CUTTERS.

As a general rule, tungsten carbide cutters should only be used when high speed steel cutters will not stand up to the hardness of the material being routed. They are not suitable for ordinary timbers and will not cut half as cleanly as high speed steel on wood.

Tungsten carbide cutters are necessary on the following materials :-

Resin bonded plywoods, wood pulped board and wall board, plastics such as Holloplast and Catalin. Linen and paper based materials, such as Tufnol and Elephantide. Aluminium alloys, die cast or wrought, containing silicon or manganese (there are certain high silicon alloys which are too hard even for tungsten carbide on the router). All sand cast aluminium castings.

Type 60, Two Edged Panel Cutter, for cutting outside profiles only. Not suitable for sinking or cutting inside profiles.

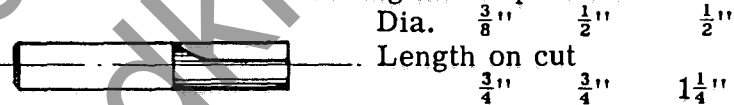

Type 61, Two edged Panel Cutter, for sinking and cutting on side.

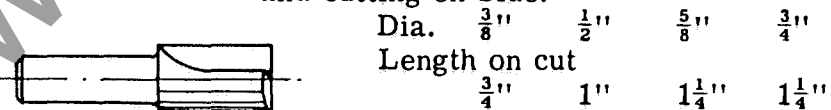

Type 62, Single Edge Spoon Bit, suitable for sinking and cutting on side.

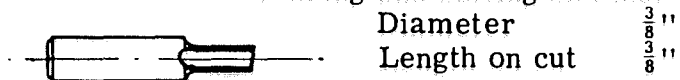

Other sizes and profile cutters of all types are available to special order.

SHARPENING TUNGSTEN CARBIDE ROUTER CUTTERS.

Tungsten carbide cutters cannot be sharpened with ordinary grinding wheels or honed with Carborundum honing stones. The grinding can be done on the N. U. Grinder and S. F. A. Attachment described on pages 45-46, using grinding wheels 86R and 87R described on page 46. Use the wheels dry; 86R for roughing, taking very light cuts, and expect to take a long time removing a small amount of carbide. Finish grind dry, using wheel 87R. In order to get a good cutting edge it is necessary to machine lap with wheel No. 145. This wheel is made from soft material and its cutting edge is impregnated with diamond dust. It is expensive to use and should be used for final finishing. It can, of course, be used for grinding in place of the 86R and 87R wheels, but the wear and cost of the laps would be prohibitive. Never attempt to true the diamond lap. When using the machine lap smear the face of the wheel with oil and then take the lightest possible cuts to get a polished face and a clean edge. Finish the cutting edge with a hand lap, which is also impregnated with diamond dust and is illustrated on page 47.

The best method of using the hand lap is to immerse the lap and tool under water and hone in this position. This is recommended so that the diamond dust freed from the lap floats to the surface of the water and does not become abrasive between the cutter and the lap, causing excessive wear on the lap. If this is not possible, use as much water as possible to swill off the diamond dust.

The general instructions on stoning cutters on pages 54-55 apply to tungsten carbide cutters except that the diamond lap is used instead of the Carborundum stone.

Tungsten carbide cutters sent out from our Works require honing with the hand lap.

CONCERNING CUTTER COLLETS.

Never over-tighten a collet. The short spanner or screw key provided is designed to give the maximum grip, when used by the average operator. The use of a pipe wrench strains the collet and actually reduces the grip on the cutter.

Never allow cutters to project from the collet more than is absolutely necessary. It is a golden rule that the nearer the cutter to the collet, the better the cut and the longer the life of the cutter.



... blow away harmful dust, chips and dirt with a Wadkin Electric Blower

No motor can run at its maximum efficiency with its ventilating duct or control gear covered with dust and dirt. Sooner or later the resultant overheating will cause serious trouble.

Similarly, accumulations of chips and dust, in the mechanical parts of the machine can interfere with its efficiency. A few minutes a week for blowing down all Woodworking Machinery will be amply repaid in better and easier running, in increased life, and freedom from breakdown.

Blowers can be supplied for single phase A.C. or Direct Current for any voltage up to 250.

Please state voltage when ordering.

